



Rotary Paddle Level Switch

INTRODUCTION

PRINCIPLE

The SE series operating principle is simple. A unit is usually located through a bin wall at the top, middle or low level of a bin. During normal operation (no material present) a synchronous motor rotates the paddle at 1 RPM. When this paddle rotation is impeded by material, surrounding the paddle, motor will stall and cause the Micro-switch to change state. (indicating an alarm or control)

APPLICATIONS

Suitable for powdery producing & processing industries such as plastic, chemical, medical, forage, cement and fertilizer powders.

FEATURES

- Airtight sealing device, outdoor application is available.
- Unique sealing ring design, it can perform good dust protection to avoid the dust permeate into housing body along with the shaft.
- The torque force is adjustable.
- The performance of torsion is stable and reliable.
- If the rotary paddle bears an extra overload, the motor will be appeared slide to prevent the inside mechanism damaged.
- It is rationally designed, the inside mechanisms are easily tore down for checking, maintenance and replacement. It doesn't necessary to remove the complete set from the tank.
- Very suitable for small tank and material of low density

STRUCTURE

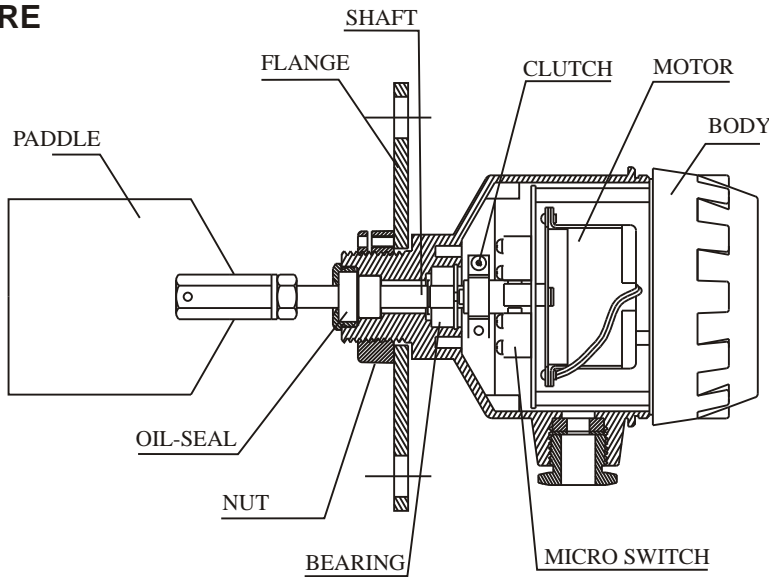

STANDARD TYPE

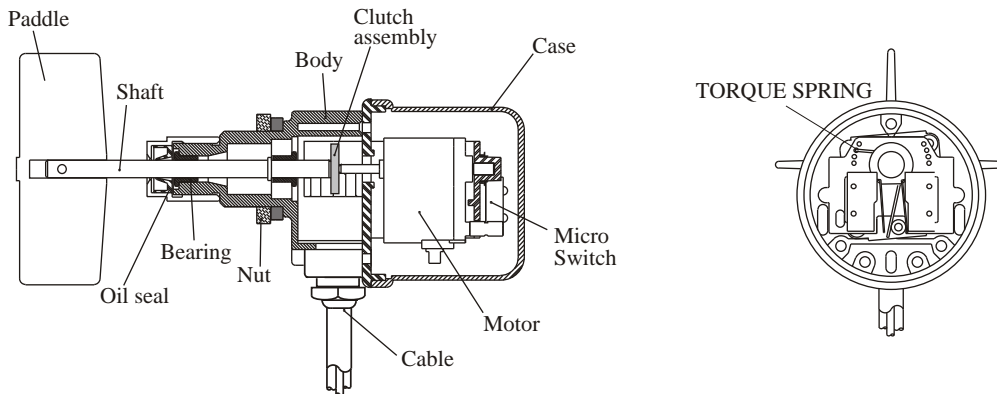

MINI TYPE

WORKING PRINCIPLE & TORQUE ADJUSTING

CONTROL SWITCH DEVICES WORKING PRINCIPLE

1. When the synchronous motor is turning. It means that material isn't touching the paddles, the (C.L) stands for "terminal point connected".
2. When material is touching the paddles, (C.L) stands for "cut-off", (C.H) stands for "connected" the synchronous motor's current is to be cut off.
3. When the material drops away from the paddles, the synchronous motor runs again and the terminal point is connected, (C.L) show that the cycle has begun again.

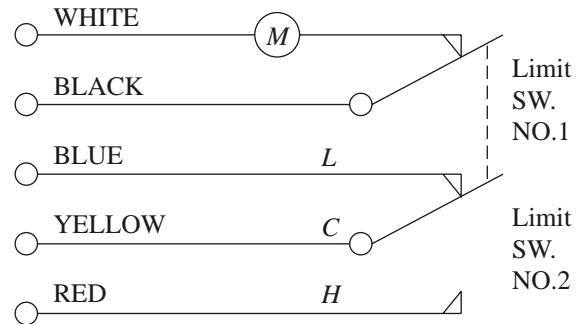

TORQUE ADJUSTING MECHANISM

The torque spring is applied to adjust the shaft output torque force, which is set at "weak" position at factory side, it is adjustable as per customer side target measuring material S.G. (special gravity), if the measured material with higher S.G., please try to release it to more stronger spring force position step until you found the proper orientation. The paddle sensitivity will

be interacted by more weaker, otherwise, the low S.G. material will release torque spring to the weakest position, which will cause the paddle performance to be more sensitive.

- Do not tamper with the spring as it may cause the Rotary Paddle to be malfunction.

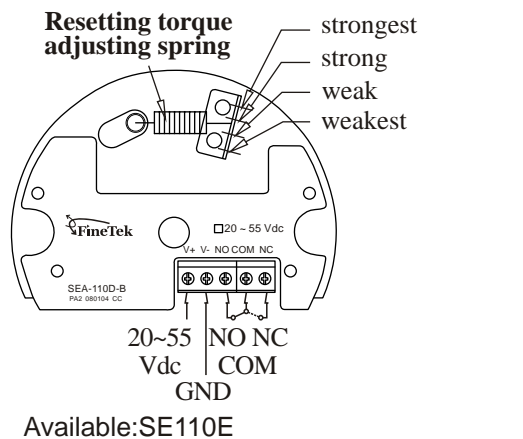
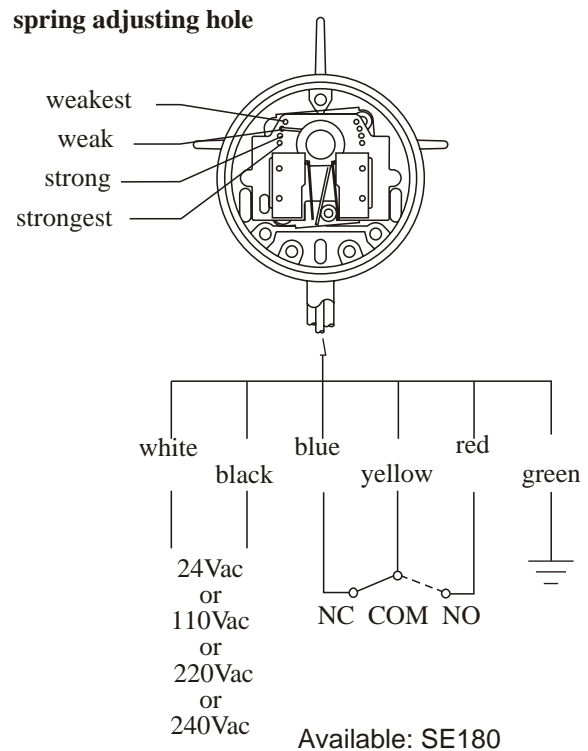
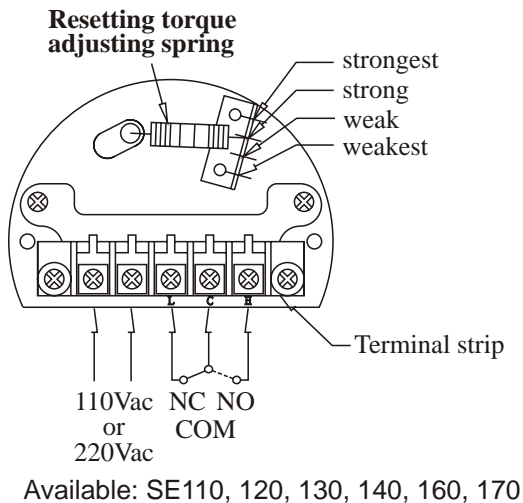

STANDARD SPECIFICATION

- **Power source** : (A)110Vac,(B)220Vac,(C)240Vac, (D)24Vac, 50/60Hz (E)24Vdc
- **Power consumption** : 3W, 11W(DC24V)
- **Contact capacity** : SPDT, 5A/250Vac
- **Rotary speed** : 1 R.P.M.
- **Insulation test voltage** : 2500V
- **Torque** : 0.5 ~1.0 kg-cm
- **Connect** : 1"PF screw or JIS 2-1/2" x 5kg/cm² flange
- **Protection/ material** : IP65 / ADC-12
- **Conduit** : 1/2"PF
- **Specific gravity** : 0.5

SE110A/B/C/D/E SCREW TYPE

- Horizontal mounting
- Operation Temp. (-20°C ~ 70°C)
- Weight: 1.2 kg

SE110A/B/C/D/E

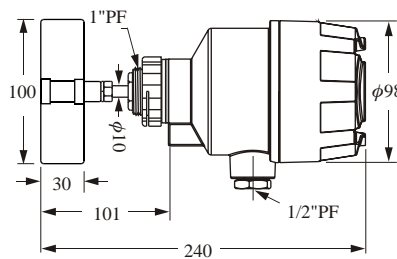

SE111A/B/C/D/E

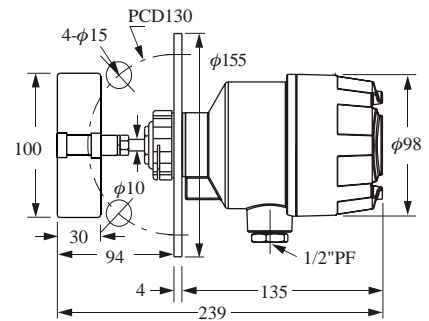

Order No. SE111A/B/C/D/E FLANGE TYPE

- Horizontal mounting
- Operation Temp. (-20°C ~ 70°C)
- Weight: 1.7 kg

SE120A/B/C/D/E SHAFT PROTECTIVE TUBE TYPE

- Horizontal /Vertical mounting
- Operation Temp. (-20°C ~ 70°C)
- Weight: 1.2 kg
- The whole section from flange to paddle are made of SUS 304
- Standard Length (option):
L--250mm (2.2 kg)
L--500mm (2.5 kg)
L--750mm (2.8 kg)
- Special length is made by order

SE120A/B/C/D/E

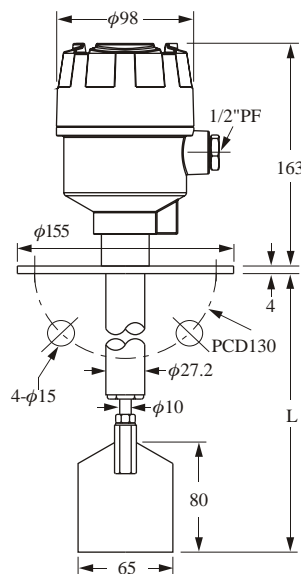

SE130A/B/C/D/E

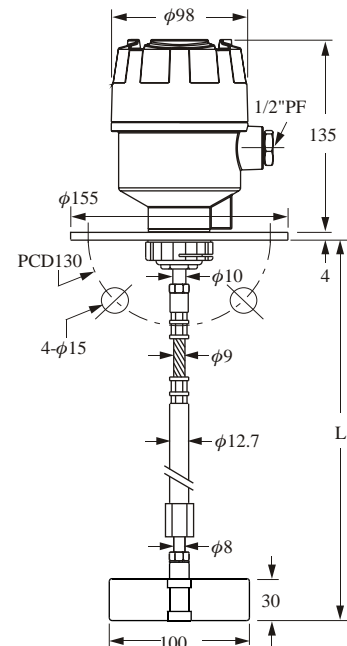

SE130A/B/C/D/E SHAFT LENGTH ADJUSTABLE TYPE

- Vertical mounting
- Operation Temp.. (-20°C ~ 70°C)
- Standard Length (option):
L-- 460 ~630mm (2.5 kg)
L-- 650 ~1000mm (2.8 kg)
L-- 760 ~1200mm (3.0 kg)
- Special length is made by order

STANDARD SPECIFICATION

- **Power source** : (A)110Vac,(B)220Vac,(C)240Vac,
(D)24Vac,50/60Hz (E)24Vdc
- **Power consumption** : 3W, 11W(DC24V)
- **Contact capacity** : SPDT, 5A/250Vac
- **Rotary speed** : 1 R.P.M.
- **Insulation test voltage** : 2500V
- **Torque** : 0.5 ~1.0 kg-cm
- **Connect** : 1"PF screw or JIS 2-1/2" x 5kg/cm² flange
- **Protection/ material** : IP65 / ADC-12
- **Conduit** : 1/2"PF
- **Specific gravity** : 0.5

SE140A/B/C/D/E HI-TEMP TYPE

- Horizontal mounting
- Temp. (-20°C ~ 200°C)
- Weight: 2.1 kg

SE140A/B/C/D/E

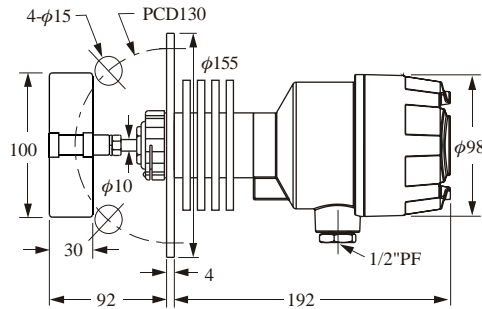

SE141A/B/C/D/E

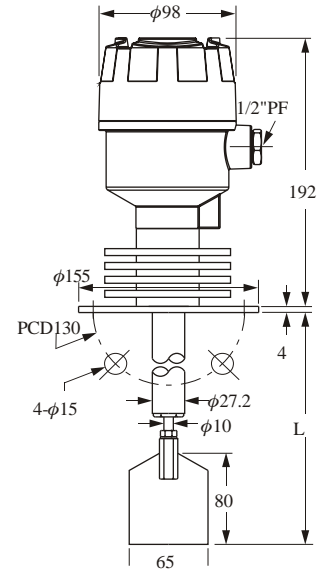

SE141A/B/C/D/E HI-TEMP SHAFT PROTECTIVE TUBE TYPE

- Horizontal /Vertical mounting
- Operation Temp. (-20°C ~ 200°C)
- The whole section from flange to paddle are made of SUS 304
- Standard Length (option):
L--250mm (2.6 kg)
L--500mm (2.9 kg)
L--750mm (3.2 kg)
- Special length is made by order

SE146A/B/C/D/E HI-TEMP SHAFT LENGTH ADJUSTABLE TYPE

- Vertical mounting
- Operation Temp. (-20°C ~ 200°C)
- Standard Length (option):
L-- 450 ~630mm (3 kg)
L-- 650 ~1000mm (3.3 kg)
L-- 760 ~1200mm (3.5 kg)
- Special length is made by order

SE146A/B/C/D/E

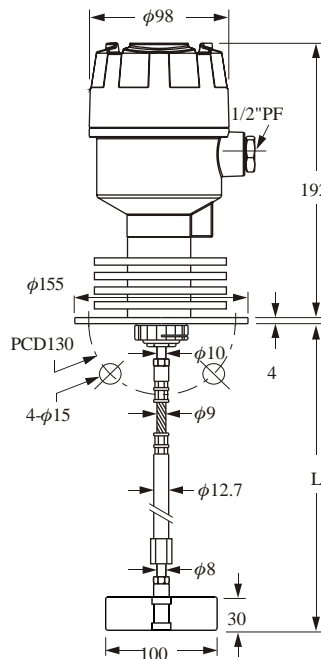

SE160A/B/C/D/E

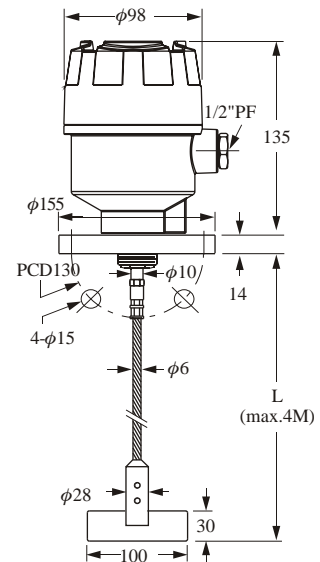

SE160A/B/C/D/E CABLE WIRE TYPE

- Vertical mounting
- Operation Temp. (-20°C ~ 70°C)
- Standard Length (option):
L-- 450mm (2.5 kg)
L-- 650mm (2.8 kg)
L-- 750mm (3 kg)
- Special length is made by order

STANDARD SPECIFICATION

- **Power source** : (A)110Vac,(B)220Vac,(C)240Vac,
(D)24Vac, 50/60Hz
- **Power consumption** : 1.5W
- **Contact capacity** : 3A/250Vac
- **Rotary speed** : 1 R.P.M.
- **Protection/ material** : IP65 / PC
- **Temp.** : -20°C ~ 70°C
- **Cable length** : 30cm (available for custom length)
- **Torque** : 30 ~100 g-cm
- **Specific gravity** : 0.3

SE280A/B/C/D CROSS-LIKE 4 BLADE PADDLE

- Horizontal mounting
- Operation Temp. (-20°C ~ 70°C)
- Weight : 0.42 kg

SE280A/B/C/D

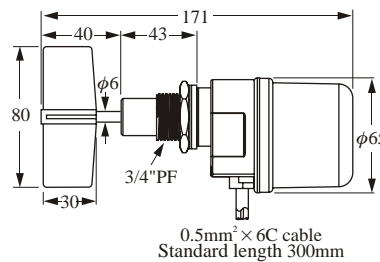

SE280□CRI

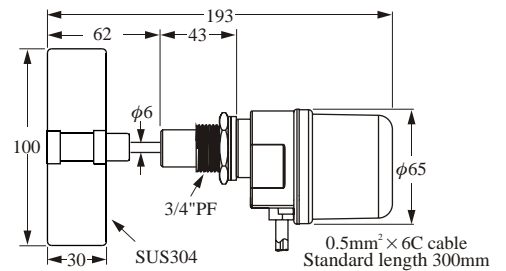

SE280□CRI RECTANGLE 100×30 SUS304 PADDLE

- Horizontal mounting
- Operation Temp. (-20°C ~ 70°C)
- Weight : 0.48 kg

SE280□CRH

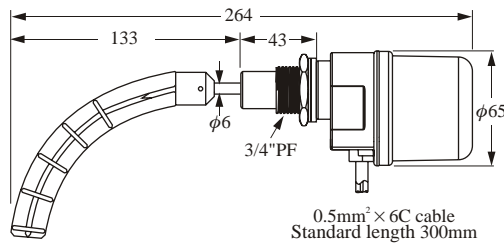

SE280□CRH SCIMITAR TYPE PADDLE

- Horizontal mounting
- Operation Temp. (-20°C ~ 70°C)
- Weight : 0.42 kg

SE282□CRI

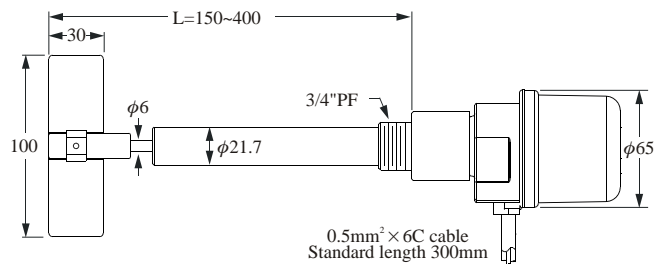

SE282□CRI SHAFT PROTECTIVE TYPE

- Horizontal /Vertical mounting
- Operation Temp. (-20°C ~ 70°C)
- Weight : 0.42 kg

SE284□CRH

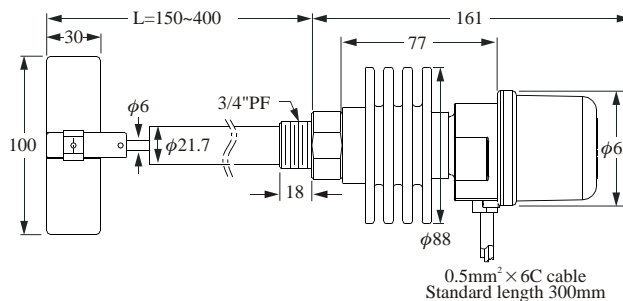

SE284□CRI HI-TEMP SHAFT PROTECTIVE TUBE TYPE

- Horizontal /Vertical mounting
- Operation Temp. (-20°C ~ 200°C)
- Weight : 01.42 kg

EXAMPLES OF MOUNTING

EXAMPLES OF MOUNTING TO TANK

Where the SE110A type paddle cannot be attached to the main shaft from inside the storage tank. The paddle can be set on the main shaft when the distance from the flange face to the tip of paddle is more than 90mm, the relative dimensions being as illustrated right.

The scimitar paddle penetrate through 3/4"PF inlet directly like illustrated drawing, then screw tightly.

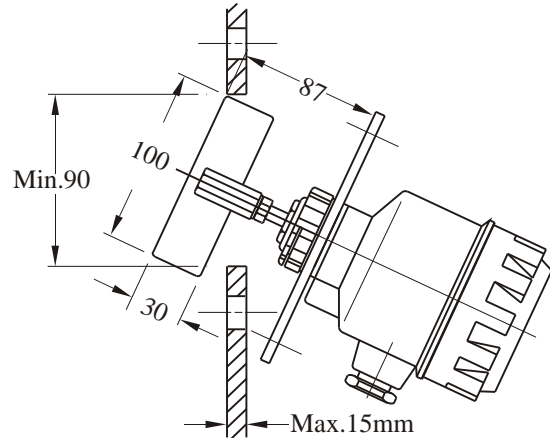
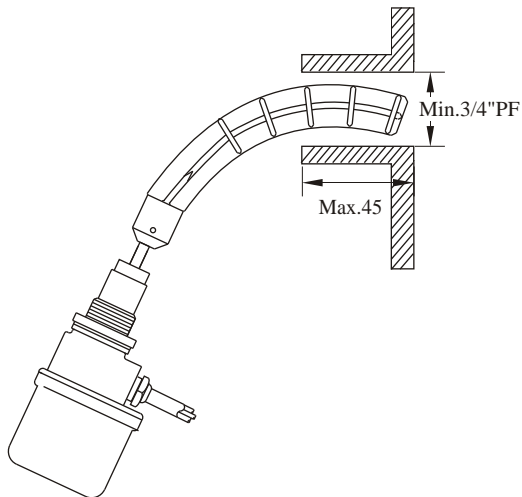

INSTALLATION EXAMPLE FOR INJECTION MOLDING MACHINE

Steps to Install the Injection Molding Machine

- Injection Molding Machine usually use Se280
- Install the Rotary Paddle through a Dia. $\phi 20$ mm Hole on the Silo
- Remove the paddle from the device by taking out the fastening pin
- Insert the SE180 through the mounting hole and tighten it
- After which, secure the Paddle to the SE180 by locking it to the shaft with the the pin
- Keep in mind to 'widen' the opening of the pin in order to secure it

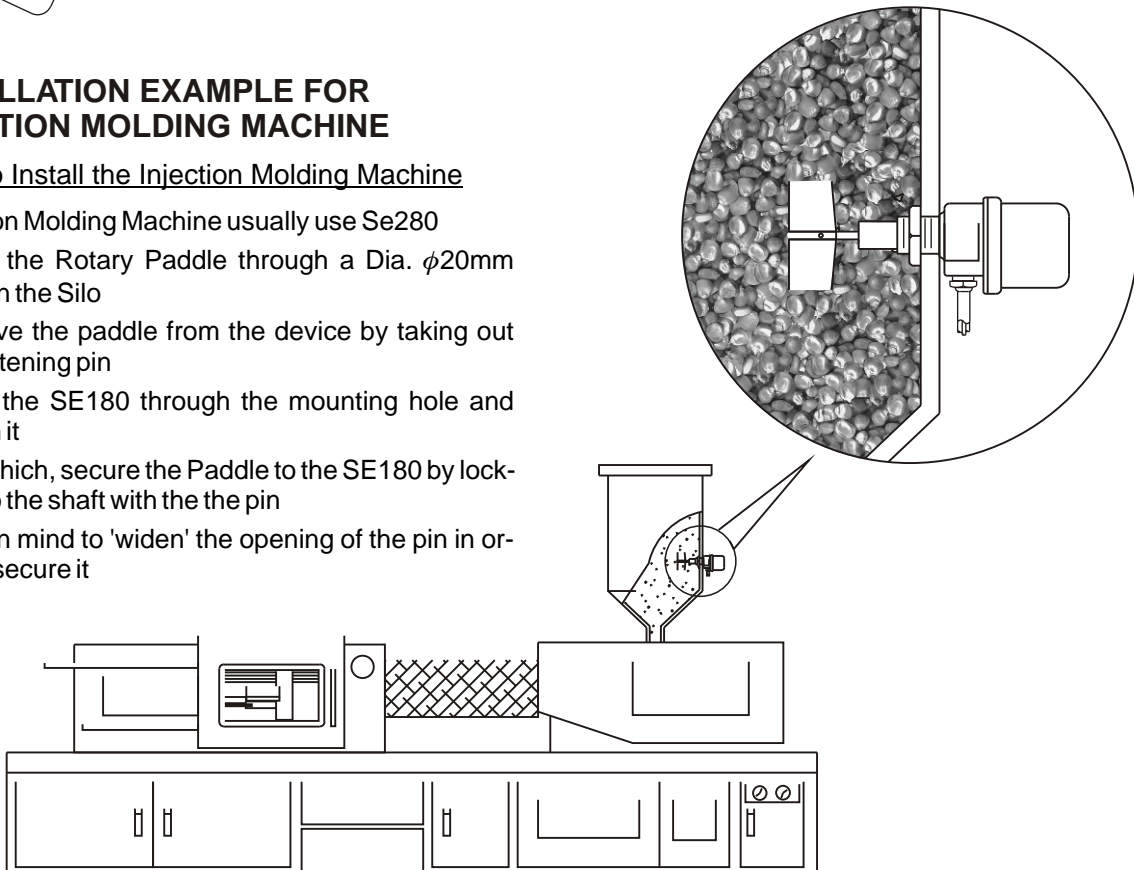

EXAMPLE

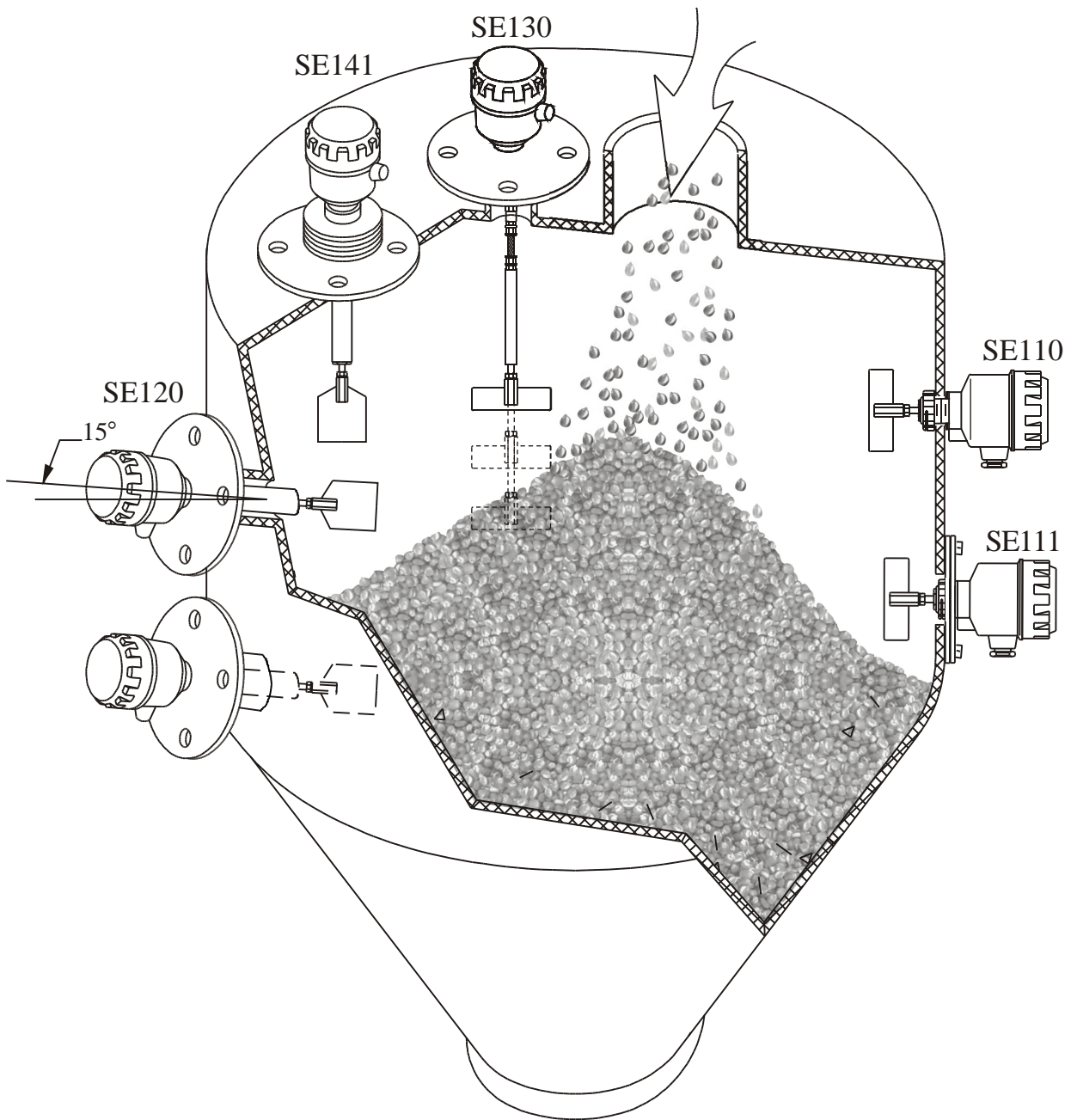

INSTALLATION NOTICES

1. Please side mount the sensor by inclined 15° ~ 20° to decrease the material inflowing impact.
2. For High Temperature application whereby the temperature inside the tank is more than 70°C
Please use SE14□ Series.
3. SE110~SE140 on 1" connection pipe inlet, please apply scimitar type to screw directly.
4. SE130, SE146 family items are with flexible and extensible shaft.
5. Please ensure that the Cable Gland point downwards and the nut must be fastened to secure the device.

ORDER INFORMATION

SE ()

MODEL NO.

- 11□ : Standard type 14□ : Hi-temp type
 120 : Shaft protective tube type 160 : Cable wire type
 130 : Shaft length adjustable type 28□ : Mini type

VOLTAGE

- A : 110Vac B : 220Vac C : 240Vac D : 24Vac
 E : 24Vdc(SE11□/120/130/14□/160) 50/60Hz

MOUNTING

Size for flange or screw		Pressure range or other
C: 3/4"	I : 4"	M: 5kg/cm ²
D: 1"	J : 5"	N: 10kg/cm ²
E: 1-1/2"	K: 6"	O: 150 Lbs
F: 2"	S: Others	P: 300 Lbs
G: 2-1/2"	3: 1-1/4"	Q: PT
H: 3"		R: PF (G)
		T : BSP
		U: NPT
		S: Others

* SE110~SE160 series:
 The size of connecting screw is 1".

PADDLE SHAPES

SE110~SE170

- A : 100 × 30 (W × H)
 B : 65 × 80 (W × H)
 C : 65 × 120 (W × H)
 D : 80 × 80 (W × H)
 E : 50 × 30 (W × H)
 F : Scimitar
 J : 200 × 28 (W × H)
 S : others - : None

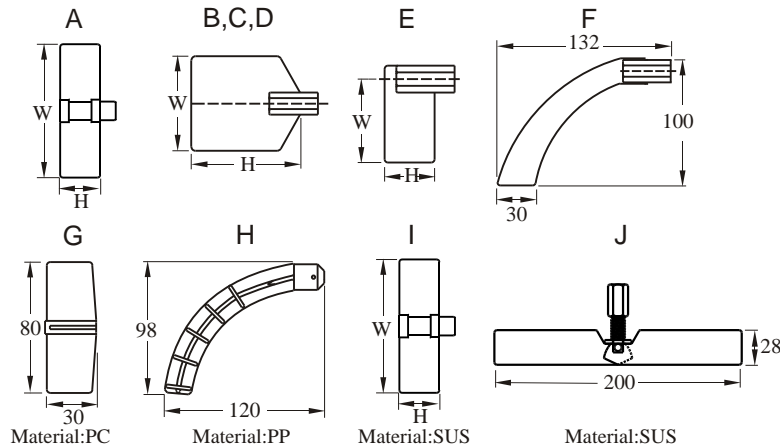

SE280 (Mini paddle type)

- G : Cross type paddle
 H : Scimitar type paddle
 I : 100x30 (WxH)

LENGTH (mm)

- 0500: below 500mm
 1000: 501~1000mm
 1500: 1001~1500mm
 :
 :

SE110~170 L: The distance from flange to paddle.
 SE280 L: Length of cable.
 The total length of item will be allowed a tolerance to ± 6mm.
 ※ 500mm per Unit
 ※ Use English letter as first code for probe length over 10m.
 A150 represents 15m, A200 represents 20m

* Order Notice

1. Please make sure the Voltage 24Vac, 110Vac, 220Vac or 240Vac, 50/60 Hz.
2. Please make sure the side or top mounting.
3. Please make sure the material specific gravity (S.G.) value.
4. Please make sure whether any bridge block or vibrating motor installed onto the tank wall.
 Please try to apply our item SA140 capacitance level sensor.
5. Please make sure the rotary paddle size is available to enter into the flange inlet.

ENCLOSURE EXPLOSION PROOF

NEPSI PROOF No. GYJ06237 Ex d IIC T3~T6
 PTB PROOF No. 05 ATEX 1029 Ex II 2G EEx d IIB T3~T6
 Ex II 2D IP65 T3~T6

- Power source : (A)110Vac, (B)220Vac, (C)240Vac, 50/60Hz
- Power consumption : 3W
- Contact capacity : SPDT, 3A/250Vac
- Rotary speed : 1 R.P.M.
- Insulation test voltage : AC 1500V x 1minute
- Torque : 0.5 ~1.0 kg-cm
- Connect : 1"PF screw or flange 1"~6" 2-1/2" x 5kg/cm² (std.)
- Enclosure material : AL Alloy, ADC-12
- Enclosure Protection : Ex d IIC T4~T6
- Conduit : 1/2" (std.) or 3/4"NPT
- Specific gravity : 0.5

SE170A/B/C/D EXPLOSION PROOF SCREW TYPE

- Horizontal mounting
- Temp. (-20°C ~ 70°C)

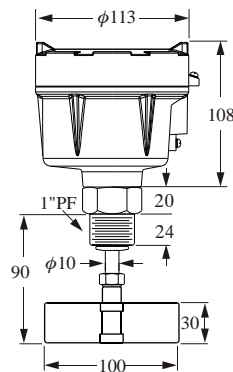

SE172A/B/C/D EXPLOSION PROOF SHAFT PROTECTIVE TUBE TYPE

- Horizontal /Vertical mounting
- Temp. (-20°C ~ 70°C)
- Standard Length (option):
L-- 250mm
L-- 500mm
L-- 750mm
- Special length is made by order

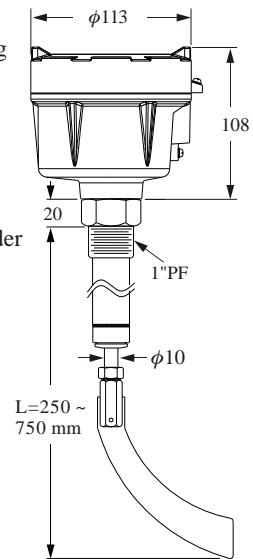

SE171A/B/C/D EXPLOSION PROOF FLANGE TYPE

- Horizontal mounting
- Temp. (-20°C ~ 70°C)

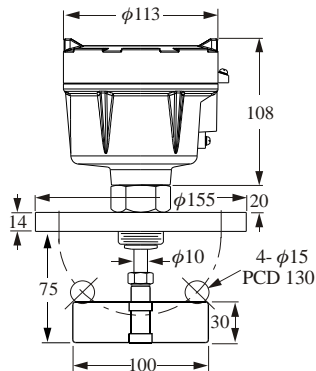

SE173A/B/C/D EXPLOSION PROOF SHAFT LENGTH ADJUSTABLE TYPE

- Vertical mounting
- Temp. (-20°C ~ 70°C)
- Standard Length (option):
L-- 450 ~630mm
L-- 650 ~1000mm
L-- 760 ~1200mm
- Special length is made by order

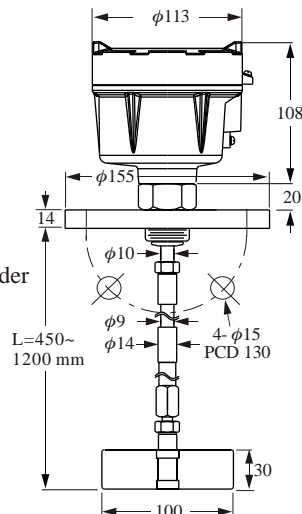

SE174A/B/C/D EXPLOSION PROOF HI-TEMP TYPE

- Horizontal mounting
- Temp. (-20°C ~ 200°C)

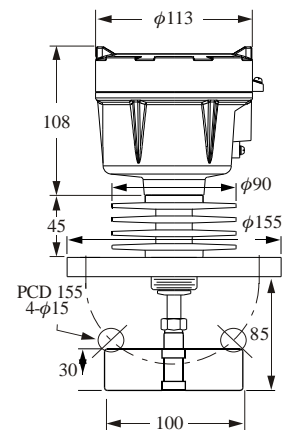

ENCLOSURE EXPLOSION PROOF

NEPSI PROOF No. GYJ06237 Ex d IIC T3~T6
 PTB PROOF No. 05 ATEX 1029 Ex II 2G EEx d IIB T3~T6
 Ex II 2D IP65 T3~T6

SE175A/B/C/D EXPLOSION PROOF HI-TEMP SHAFT PROTECTIVE TUBE TYPE

- Horizontal /Vertical mounting
- Temp. (-20°C ~ 200°C)
- Special length is made by order

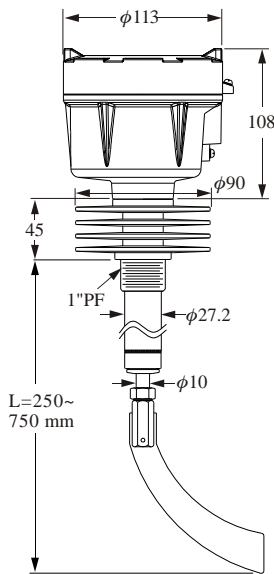

SE176A/B/C/D EXPLOSION PROOF HI-TEMP SHAFT LENGTH ADJUSTABLE TYPE

- Vertical mounting
- Temp. (-20°C ~ 200°C)
- Special length is made by order

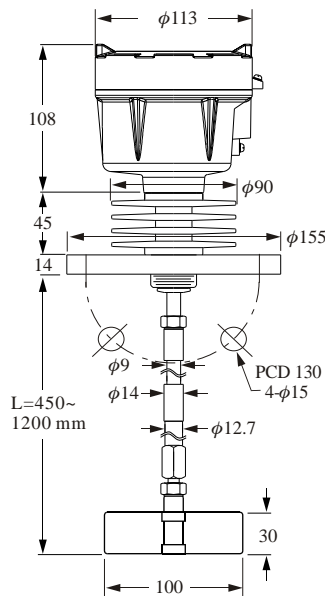

SE177A/B/C/D EXPLOSION PROOF CABLE WIRE TYPE

- Vertical mounting
- Temp. (-20°C ~ 70°C)
- Special length is made by order

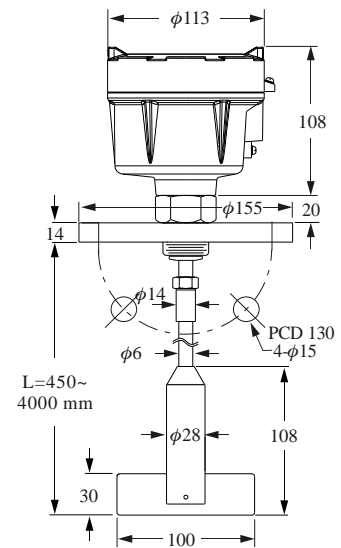

■ Paddle Introduction (Big)

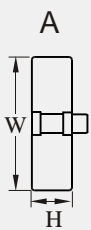

(A) 100x30 (WxH), Min. fixed hole diameter size φ90mm.

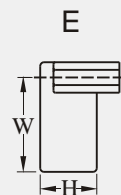

(E) 50x30 (WxH), Suitable for high S.G. raw material, application by small size paddle to decrease the material flowing impact directly.

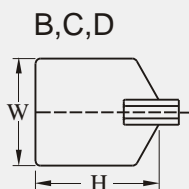

(B) 65x80 (WxH), Directly mounted into 2" fixed hole.
 (C) 65x120 (WxH), Directly mounted into 2" fixed hole.
 (D) 80x80 (WxH)

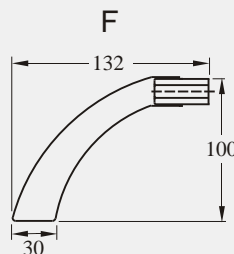

(F) Scimiter type paddle, Directly screwed through 1" diameter fixed hole, It is more easy to be mounted dispense with labor of tank cut-out.

ORDER INFORMATION

SE1 **7** ()

MODEL NO. _____

- | | |
|-----------------------------------|---|
| 70 : Screw type | 74 : Hi-temp type |
| 71 : Flange type | 75 : Hi-temp shaft protective tube type |
| 72 : Shaft protective tube type | 76 : Hi-temp shaft length adjustable type |
| 73 : Shaft length adjustable type | 77 : Cable wire type |

VOLTAGE _____

A : 110Vac B : 220Vac C : 240Vac

MOUNTING _____

Size for flange or screw		Pressure range or other
C : 3/4"	I : 4"	M : 5kg/cm ²
D : 1"	J : 5"	N : 10kg/cm ²
E : 1-1/2"	K : 6"	O : 150 Lbs
F : 2"	S : Others	P : 300 Lbs
G : 2-1/2"	3 : 1-1/4"	Q : PT
H : 3"		R : PF (G)
		T : BSP
		U : NPT
		S : Others

PADDLE SHAPES _____

- A : 100x30 (WxH)
- B : 65x80 (WxH)
- C : 65x120 (WxH)
- D : 80x80 (WxH)
- E : 50x30 (WxH)
- F : Scimitar
- S : Others

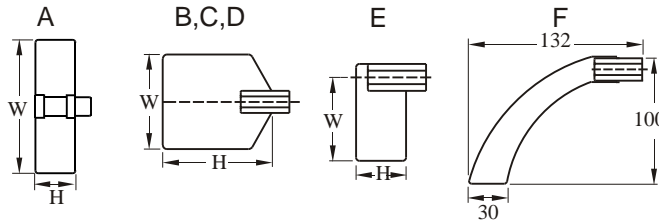

LENGTH (mm) _____

- 0500: below 500mm
 - 1000: 501~1000mm
 - 1500: 1001~1500mm
 - ⋮
- ※ 500mm per Unit
 ※ Use English letter as first code for probe length over 10m.
 A150 represents 15m, A200 represents 20m
- The total length of item will be allowed a tolerance to 6mm.

*** Order Notice**

1. Please make sure the Voltage 24Vac, 110Vac, 220Vac or 240Vac, 50/60 Hz.
2. Please make sure the side or top mounting.
3. Please make sure the material specific gravity (S.G.) value.
4. Please make sure whether any bridge block or vibrating motor installed onto the tank wall.
Please try to apply our item SA140 capacity sensor.
5. Please make sure the rotary paddle size is available to enter into the flange inlet.

EXAMPLES-OF-TANK-MOUNTING

- [FC/FD] Mini Float/Magnetic Float Level Switch
- [FG] Magnetic Float Level Transmitter
- [FF] Side Mounting Float Switch
- [FA/FB] Cable Float Level Switch
- [SP] Thermal Dispersion Flow Switch
- [SF] Paddle Flow Switch
- [SD] Optical Level Switch
- [SE] Rotary Paddle Level Switch
- [SA] Capacitance Level Switch
- [EC] Pressure Level Transmitter
- [LR] Loop Power Indicator
- [SC] Vibrating Probe Level Switch
- [SC] Tuning Fork Level Switch
- [EB] RF-Capacitance Level Transmitter
- [SB] RF-Capacitance / Admittance Level Switch
- [EG] Magnetostrictive Level Transmitter
- [EF] By-Pass Level Transmitter
- [MEF] Mini By-Pass Level Transmitter
- [EA] Ultrasonic Level Transmitter
- [JFR] FMCW Radar Level Transmitter
- [EE] Electromechanical Level Measuring System
- [ED] Speed Monitor
- [SRT/SRS] Conveyor Belt Misalignment Switch & Safety Cable Pull Switch
- [PB/PM] Microprocessor Based Bargraphic Display Scaling Meter
- [BRD/AE] Valve and Controller for Dust Collector System
- [BAS/BAH/BVP] Air Hammer
- [BVK/BVR/BVT] Pneumatic Vibrator

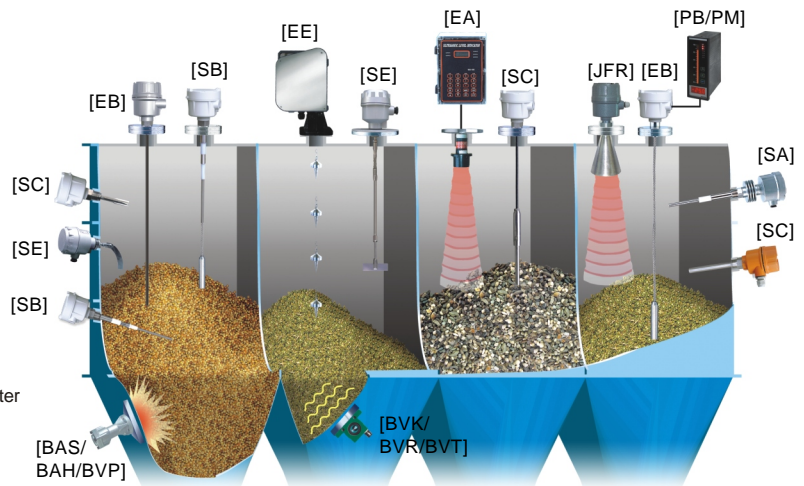
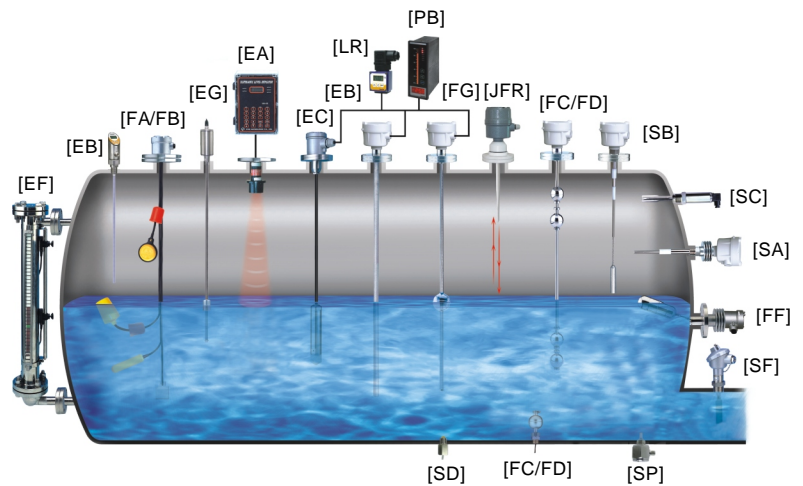

FineTek Co., Ltd.

No.16, Tzuchiang St., Tucheng Industrial Park, New Taipei City 236, Taiwan
 TEL: +886-2-2269-6789 FAX: +886-2-2268-6682
 Email: info@fine-tek.com http://www.fine-tek.com

Fine automation (Shanghai) Co., Ltd.

No.451 DuHui Rd, MinHang District, Shanghai, China 201109
 TEL: +86-21-6490-7260 FAX: +86-21-6490-7276
 Email: info.sh@fine-tek.com

FineTek Pte Ltd.

No. 11 Kaki Bukit Road 1, #04-01 Eunos
 Technolink 415939, Singapore
 TEL: +65-6452-6340 FAX: +65-6734-1878
 Email: info.sg@fine-tek.com

FineTeK GmbH

Frankfurter Str. 62, OG D-65428 Ruesselsehim, Germany
 TEL: +49-(0)6142-17608-0 FAX: +49-(0)6142-17608-20
 E-Mail: info@fine-tek.de



Distributor:

