

DESCRIPTION

The Float Switches are made of molded, chemical resistant polypropylene, that it was serviceable, low-cost, and specially designed to solve the long distance, multi-points level detection, liquid with pump or granule instances. Certainly, it's suitable for common liquid also.

PRINCIPLE

CS1 Type float switch make use of micro switch as contact component. The switch will have ON or OFF contact signal output when the angle is larger than 28°

CF Type float switch make use of mercury switch as contact component. When liquid lift up to contact float, the float will have variable angles. The switch will have ON or OFF contact signal output when the angle is larger than 10°

SPECIFICATION

Type	CS1-R A/B/C	CS1-P A/B/C	CF-S A/B/C
Float Material	Polypropylene	Polypropylene	SUS304
Cable Specification	Neoprene Cable 1mm ² x3C or 2C	PVC(VCT) Cable 1mm ² x3C or 2C	Silicon Cable 0.75mm ² x3C or 2C
Contact Rating	10A/250VAC, 15A/250VAC		2A/250VAC
Contact Form	1A, 1B or 1C		
Operating Temp.	-10°C~80°C	0°C~60°C	0°C~170°C
Suitable S.G.	0.6		0.5
Weight Approx.	770g / 5M		480g / 5M

CONTACT FORM

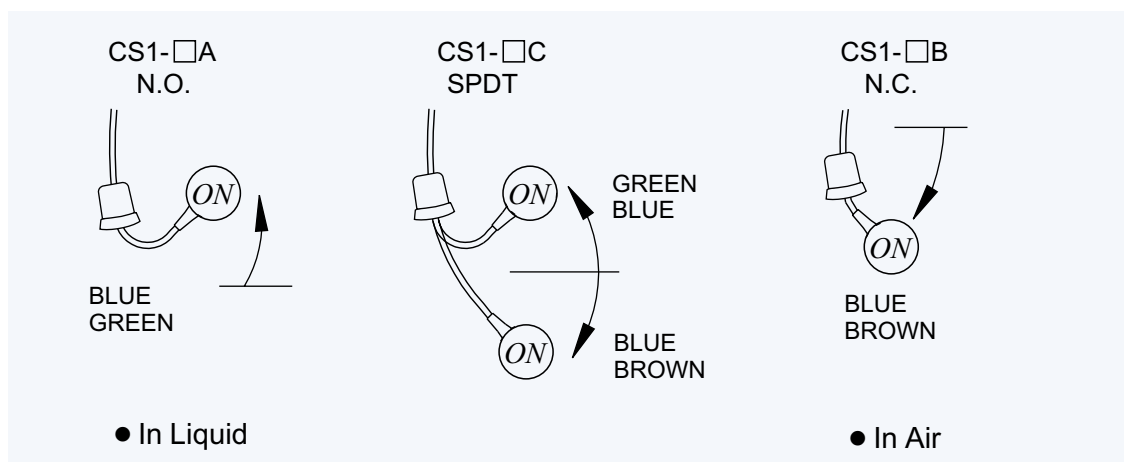

STRUCTURE & DIMENSION

CF TYPE

1. Silicon Cable
2. Material: SUS304
Enclosure IP68
3. Mercury Switch: 2A/250VAC

CS1 TYPE

1. Neoprene Cable or PVC(VCT) Cable
2. Material: PP
Enclosure IP68
3. Micro Switch: 10A/250VAC
4. Steel Ball: 15A/250VAC

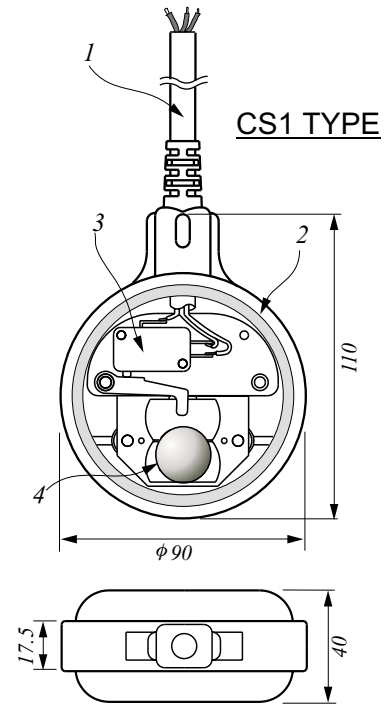
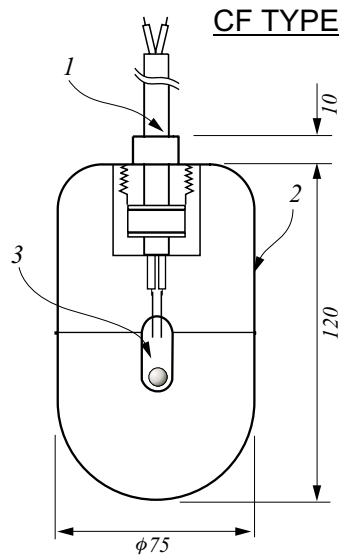

DIMENSION OF WEIGHT



CS1-PP-W

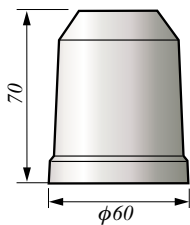

CF-SUS-W

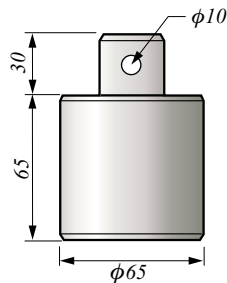

Type	Material	Weight
CS1-PP-W	P.P.	0.2kg
CF-SUS-W	SUS304	1.8kg

FLOAT TYPE CODE

CF-SA-□□

Cable length
 x6---0.6M 10--- 10M
 03--- 3M 15--- 15M
 05--- 5M Max. 20M

A --- N.O.
 B --- N.C.
 C --- SPDT

CS1-RA-□□

Cable length
 x6---0.6M 10--- 10M
 03--- 3M 15--- 15M
 05--- 5M Max. 20M

A --- N.O.
 B --- N.C.
 C --- SPDT

Cable material
 P --- PVC (VCT)
 R --- Neoprene <HAR>H07RN

RUBBER CABLE CHEMICAL RESISTANCE

Liquids	CS1-R	CS1-P	CF-S	Liquids	CS1-R	CS1-P	CF-S
Diesel	○	○	○	Acetic acid (less than 10%)	✓	✓	✓
Glycerine	○	○	○	Formaldehyde (less than 40%)	✓	✓	✓
Fuel-oil	○	○	○	Lactic acid (less than 10%)	✓	✓	✓
Washing agent	○	○	○	Nitric (less than 10%)	✓	✓	✓
Benzine	○	○	○	Hydrochloric acid (less than 10%)	✓	✓	✗
Formic acid (less than 10%)	✓	✓	✓	Sulfuric acid (less than 30%)	✓	✓	✗

○ Excellent ✓ Acceptable ✗ Not good

APPLICATION

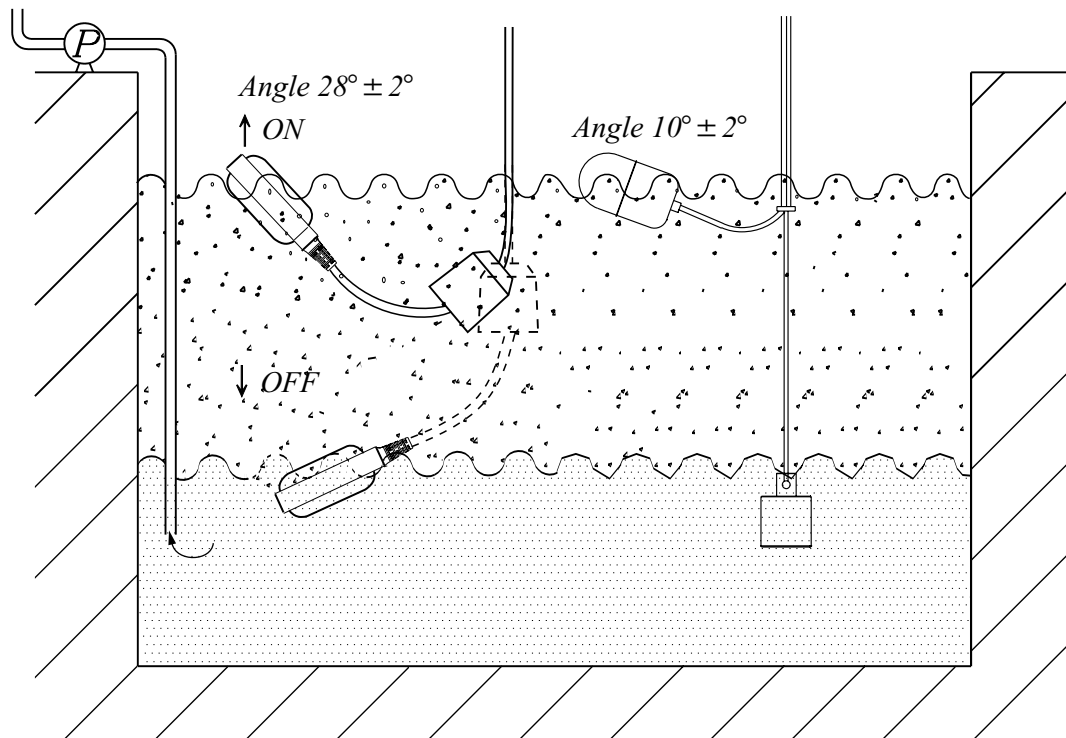

RELATIVE DIMENSION FOR INSTALLATION

The float action length (a) must be less than the distance between wall and cable (A) ; if not will cause wrong action.

Keep inlet of pump (D) lower than the float (d) , to prevent damage from lack of water.

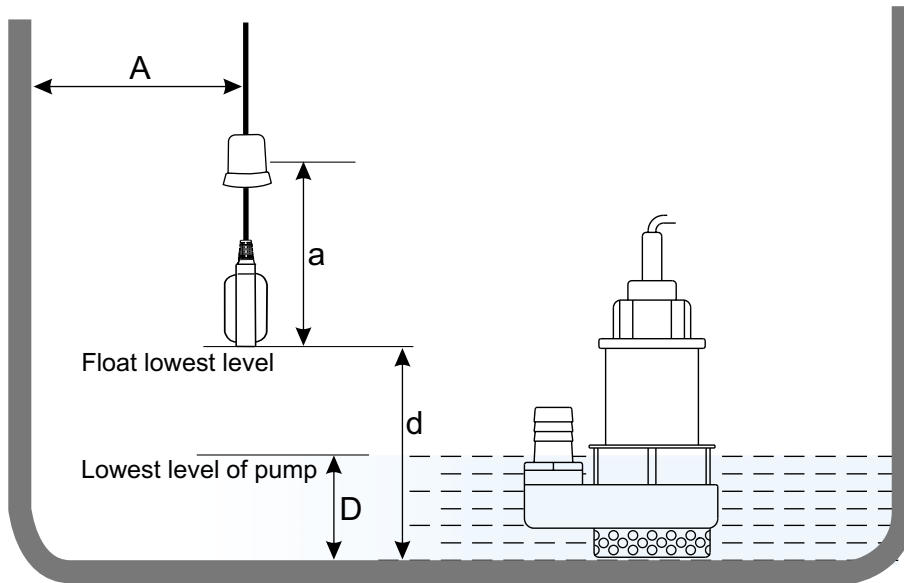

ATTENTION TO INSTALL

Keep a proper distance between installation position and inlet of water pump, to prevent float sucked by inlet of water pump.

Between installation position and inlet of water should keep a proper distance to prevent impacting water and cause wrong action. If it can't be avoided, to install wave-resistance pipe or wave-resistance plate for improvement.

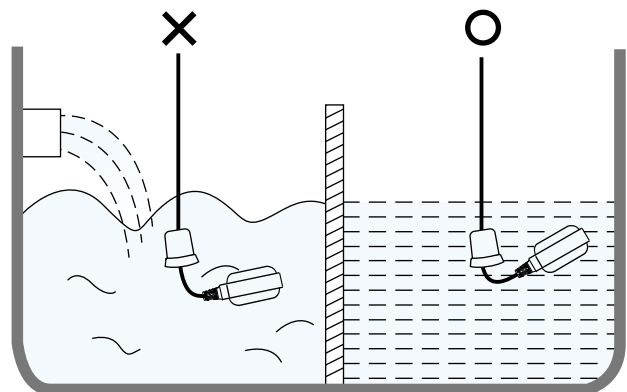
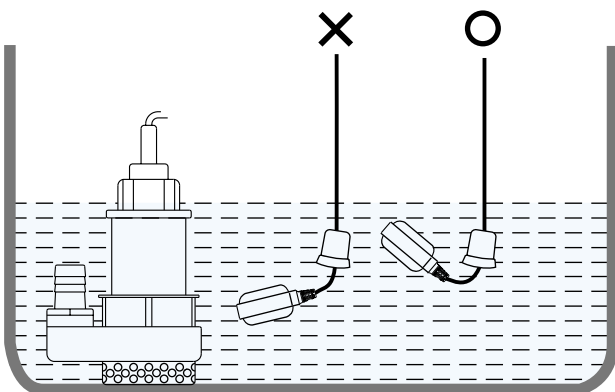

HOW TO ORDER FL TYPE

Various types of multi-point products can be selected depends on user's requirement.

For examples:

FL-B type is suitable for Corrosive liquid.

FL-A type is suitable for high temp liquid.(170°C)

DISTANCES OF CONTROL POINT

	NO	NC
l_1 : _____ mm	<input type="checkbox"/>	<input type="checkbox"/>
l_2 : _____ mm	<input type="checkbox"/>	<input type="checkbox"/>
l_3 : _____ mm	<input type="checkbox"/>	<input type="checkbox"/>
l_4 : _____ mm	<input type="checkbox"/>	<input type="checkbox"/>
L : _____ mm		

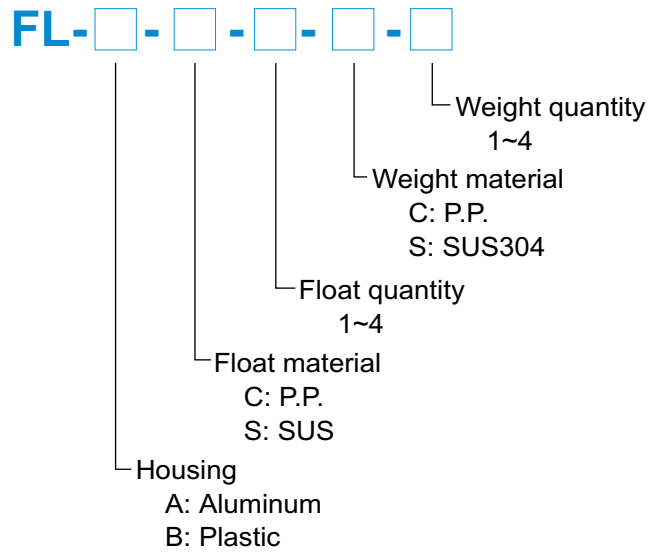

MODEL: FL-A

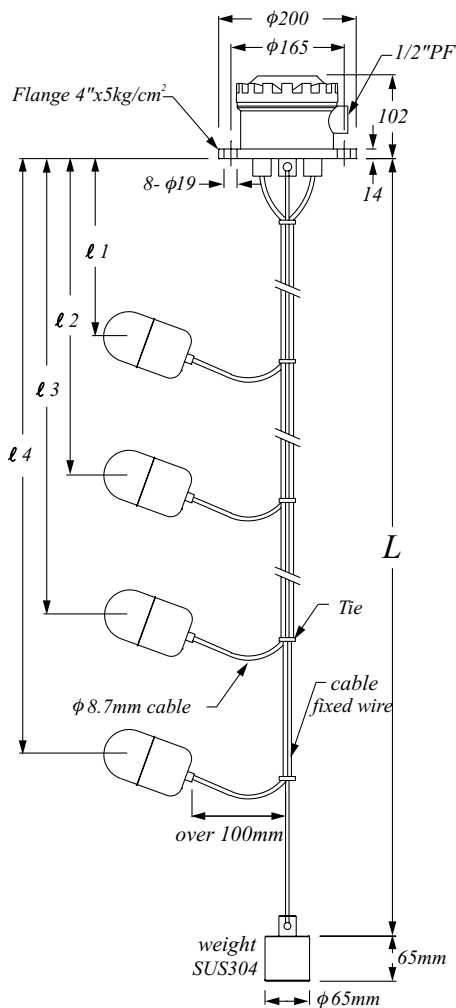

MODEL: FL-B

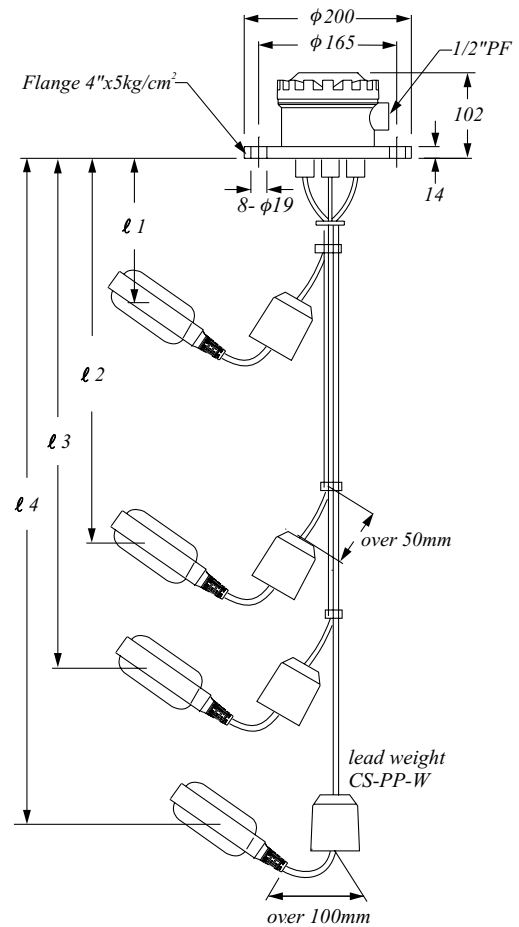

TYPE APPLICATION

The FL-B Type is suitable for install on the roof of tank and suspend floats in tank's inside for pumping control with level alarms.

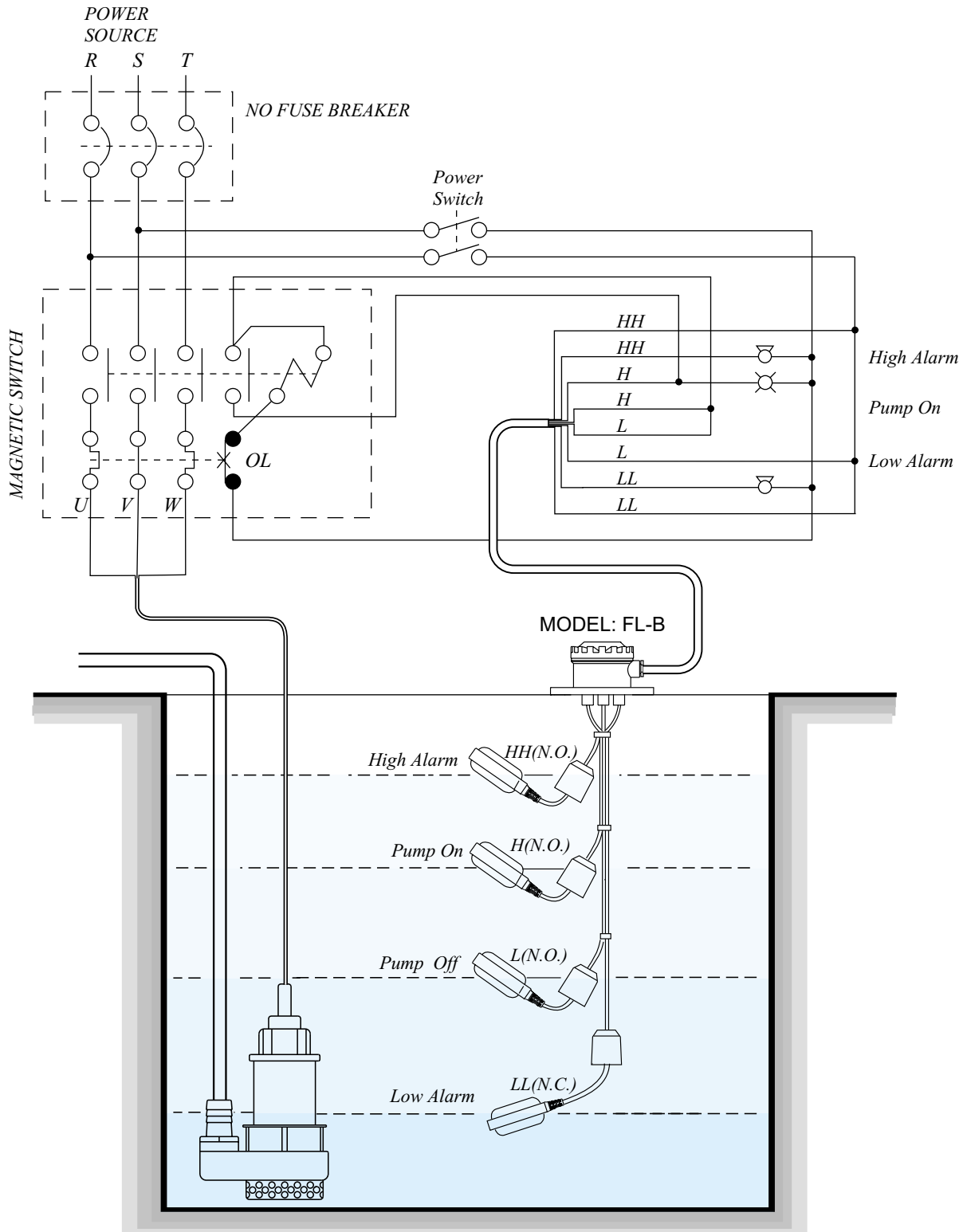

NEW

MODEL: SK TYPE

- Cable: Neoprene <HAR>H07RN
- Float: Material---PP
Enclosure---IP68
- Micro Switch: 10A/250VAC
- Steel Ball

SK-RA -

Cable length
x6---0.6M
06--- 6M

DIMENSION

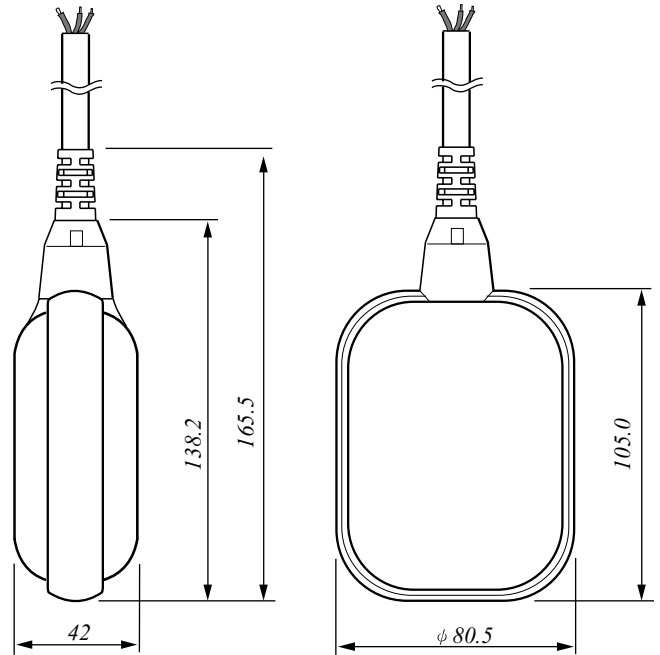

SPECIFICATION

Float Material	<i>Polypropylene</i>
Cable Specification	<i>Neoprene Cable 1mm² × 3C</i>
Contact Rating	<i>10A/250VAC</i>
Contact Form	<i>NC</i>
Operating Temp.	<i>85°C</i>
Operating Pressure	<i>1 Bar (max.)</i>
Action Angel	<i>± 45°</i>
Weight Approx.	<i>221g/0.3M</i>

APPROVALS

