

**TECFLUID**

instrumentation  
for fluids

**Variable Area  
Flowmeter**  
Series

**2100 / 2150 / 2300 / 2340**



## Instructions Manual



### Technical characteristics

- Precision according to VDE/VDI 3513:
    - 2100  $\pm 4\%$  f. s. value Class 4
    - 2150  $\pm 2,5\%$  f. s. value Class 2,5
    - 2300/2340  $\pm 1,6\%$  f. s. value Class 1,6
  - Standard Scales:
    - Water in l/h.
    - Air in NI/h up to 700 NI/h.
    - Air in Nm<sup>3</sup>/h from 1 to 17 Nm<sup>3</sup>/h. (on demand in l/s, cc/min, %.)
  - Mounting: Vertical (rising fluid).
  - Fittings:
    - 2100/2150/2300 Rp 1/4" (BSP) or 1/4" NPT
    - 2340 Rp 1/2", Rp 3/4" (BSP) or 1/2", 3/4" NPT
  - Materials:
    - Metering tube: Borosilicate Glass
    - Fittings: EN 1.4404 (AISI-316L)
    - Float: EN 1.4404 (AISI-316L), Aluminium, Glass, Ceramic PVC, PVDF, PTFE.
    - Valve: EN 1.4404 (AISI-316L)
    - Valve seat: PTFE
    - Gaskets: NBR (Nitrile Rubber) (Viton<sup>®</sup> on demand)
  - Working Pressure: 15 bar max.
  - Fluid temperature: 0 ... +120°C.
  - Ambient temperature: 0 ... +80°C.
- Conforms with Directive 97/23/CE
- Optional limit switches:
    - 20-AMD  
Bi-stable inductive proximity detector, NAMUR DIN 19234  
Conforms with Directive EMC 89/336/EEC
  - 20-AMO  
Optical limit switch (for clear fluids).
    - Power supply:  
12 VDC, 24 VDC, 24 VAC,  
110 VAC, 230 VAC, 240 VAC.



### Working Principle

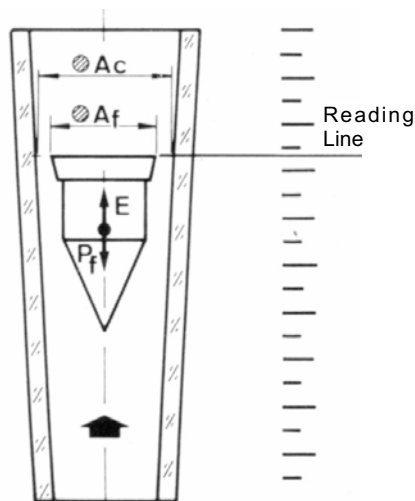

The flowmeter consists of a float inside a conical tube.

The rising flow pushes the float to an equilibrium point. The area obtained between the float and the tube is proportional to the flow rate.

This type of measuring principle is known as variable area.

The equilibrium point depends on :

- The float weight : Pf
- The fluid thrust : E
- The free flow area : Af

The area proportional to the flow rate will be:

$$A_l = A_c - A_f$$

where:

- A<sub>c</sub> = Flow metering tube area
- A<sub>f</sub> = Float area

Each position of the float corresponds to a flow rate indicated on the scale printed on metering tube.

### RECEPCIÓN

The flowmeter is supplied ready for use.

Turning the apparatus carefully upside down, check that the float moves freely.

### MOUNTING

The flowmeter must be mounted vertically taking into account that:

The fluid inlet is at the bottom (the low end of the scale).

The fluid outlet is at the top (the high end of the scale).

It is most important that the flowmeter is installed perfectly vertical, given that deviations of the order of 5-10° from the vertical can produce reading errors of up to 10%.

### FLOW RATE READING

The float determines the flow rate measurement on the scale.

For the different shapes of floats, the readings must be taken at the height shown in the drawing at the right.

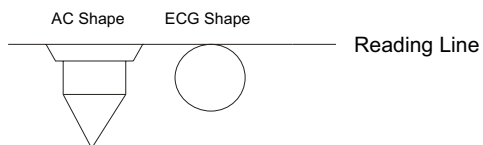

### CLEANING AND MAINTENANCE

To dismount the metering tube for cleaning proceed as following:

Turn the press (1) clockwise between a half turn and one and a half turns, depending on the model, to free the metering tube.

Remove the springs or stops (3 & 5) and the float (4). Cleaning should be done using a soft brush (bottle brush or similar) to avoid scratching the measuring tube.

The float should also be cleaned with a soft brush, never with metallic utensils which could scratch it's surface

Next mount the float (4), and then the springs or stops (3 & 5) and then place the gaskets (2 & 6) well centred in their seatings with the aid of the metering tube.

Centre the metering tube and gently tighten the press (1) anti-clockwise until a seal is obtained.

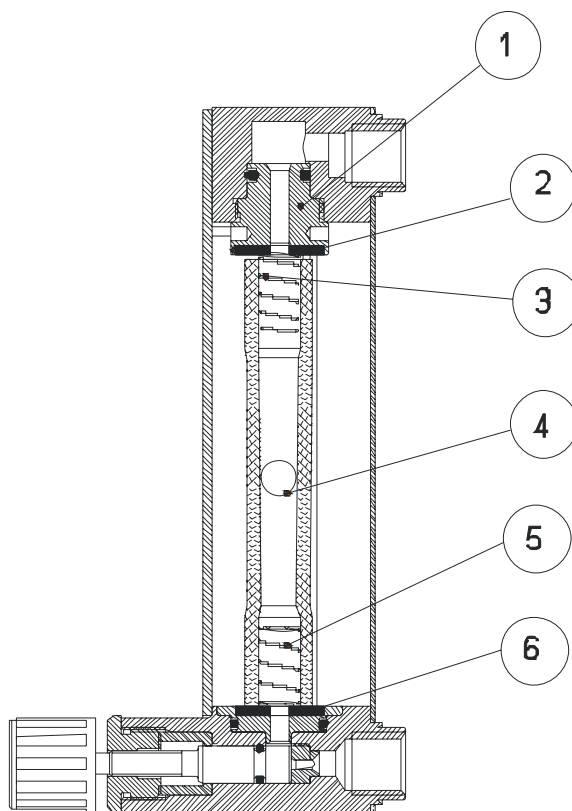

## **WARRANTY**

Tecfluid S.A. GUARANTEES ALL ITS PRODUCTS FOR A PERIOD OF 24 MONTHS, after consignment, against all defects in materials and workmanship.

This warranty does not cover failures which can be imputed to misuse, use in an application different to that specified in the order, the result of service or modification by un-authorized persons, bad handling or accident.

This warranty is limited to cover the repair or replacement defective parts which have not been damaged by misuse.

This warranty is limited to the repair of the equipment and all further and eventually following damages are not covered by this warranty.

Any consignment of equipment to our factory or distributor must be previously authorised. The consignment should be done with the equipment well packed, clean of any liquids, grease or hazardous materials. Tecfluid S.A. will not accept any responsibility for damage done during transport.

Together with the equipment, a note should be enclosed indicating the failure observed, the name, address and telephone number of the sender. .

---

TECFLUID, S.A.  
Narcís Monturiol, 33  
E-08960 Sant Just Desvern  
Tel. + 34 93 3724511 - Fax + 34 93 4734449  
E-mail: [tecfluid@tecfluid.com](mailto:tecfluid@tecfluid.com)  
Internet: [www.tecfluid.com](http://www.tecfluid.com)

---

The technical data in this pamphlet is subject to modification without notification.