

SR Series

Spring Return dosing pump
FM - mechanical diaphragm

FM



DOSEURO®

The right dosing choice



SR Series

Type FM

SOME REASONS TO PREFER OUR PRODUCTS

Versatility

A wide range of models and executions are available to suit very different applications, starting from 4 up to 50 l/h

Reliability

The high level of accuracy and reproducibility with the high quality of the materials selected make the mechanical diaphragm SR series to assure the maximum reliability.

Quality

The best performances in all applications are achieved through the optimal selection of the components and the peculiar structure of their diaphragms.

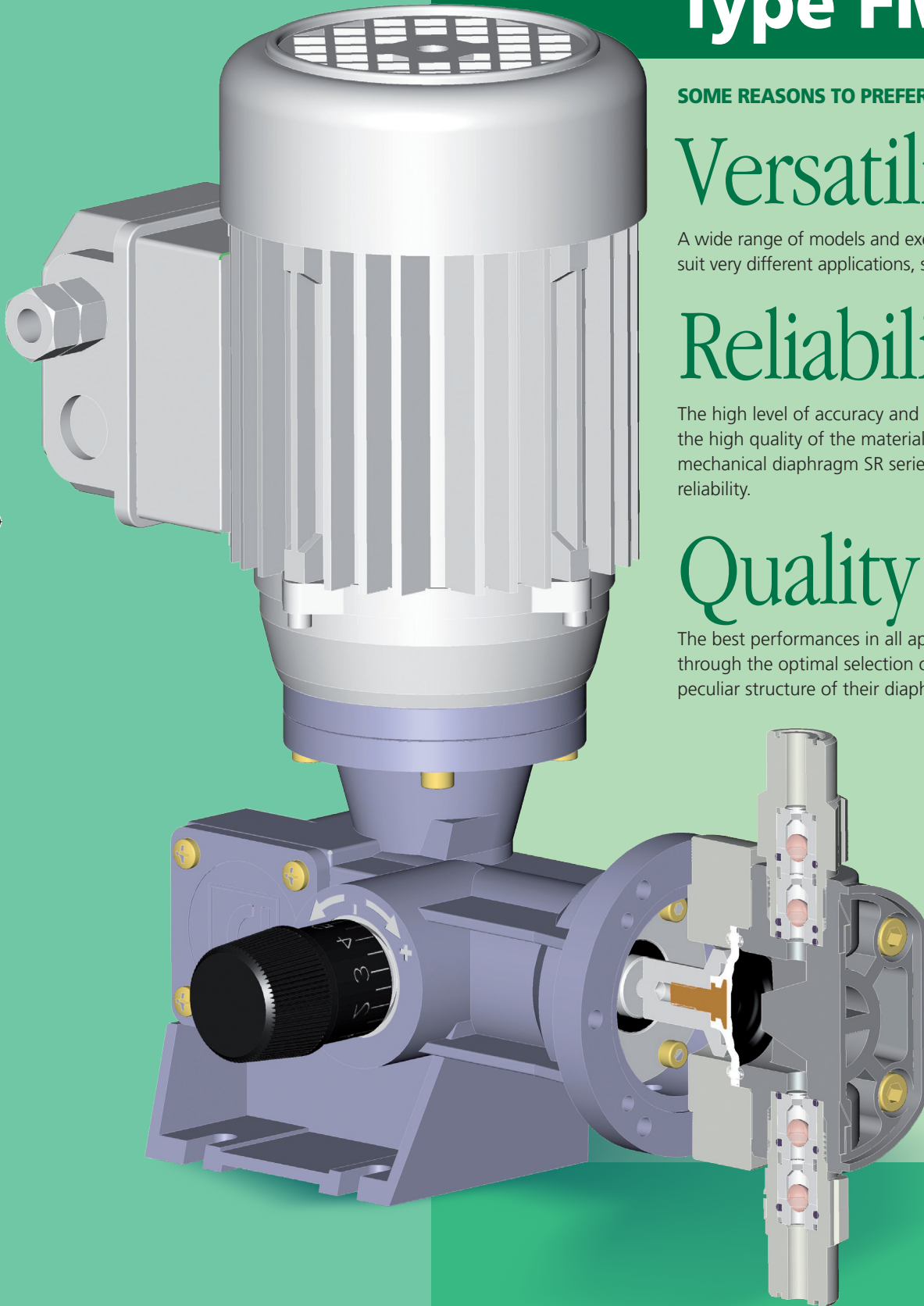

Spring Return Mechanical Diaphragm Dosing Pumps



FEATURES

Mechanical Diaphragm pumps are suitable for the applications in which:

- the dosed liquid contains small amounts of particles in suspension
- the dosed liquid contains toxic solutions
- a drip proof/air tight application is required
- high pressures are not required

Each pump is built with a standard gearbox reduction system and a vertically mounted B14 shaped electric motor in compliance with UNEL-MEC specifications.

Motors power is usually 0,09 Kw with 4 poles: 3-phase 230/400 Volts 50/60 Hz, and single phase 230V/50 Hz or 110V/60 Hz.

As they are motors complying to UNEL-MEC specifications, there are many available options with different voltages, frequencies and insulation classes, whereas explosion proof versions are not allowed.

The gearbox is worm wheel type and helicoidal reduction system with all bearings supported within a fully lubricated gearbox.

The mechanism for the variation of the capacity is spring return based operated by an eccentric; this makes the diaphragm move forward (pushing phase) for all the stroke length, while the spring in continuous tension causes the comeback of the diaphragm (suction phase).

PUMPING HEADS

Pumping heads standard executions are mostly in S.S. 316, PVC and Polypropylene.

Executions in other materials such as PTFE,

PVDF and so on are available on request.

Maximum temperature of the liquid to dose:

- 60° C with S.S. 316 pump head
- 40° C with PVC pump head

Jacketed pump heads for either cooling or heating are available to suit requirements.

DIAPHRAGM

They are manufactured in PTFE / NBR.

SUCTION AND DISCHARGE CONNECTIONS

Suction and discharge connections are usually G.m. threaded, but they can be supplied UNI or ANSI flanged as well. All pumps have double ball valves as standard execution.

STROKE ADJUSTMENT

The variation of the stroke length for the flow rate adjustment is manual. It is possible to modify the flow rate when the pump is either running or inactive.

CHARACTERISTICS

Mechanical diaphragm FM pumps are available in one size only:

FM 050 stroke length 5 mm

For this model, two diaphragm sizes are available to fulfill every different requirements for capacity and pressure.

ACCESSORIES

Each FM pump* comes with a complete set of accessories suitable for the optimal installation and operative conditions:

- injection valve
- strainer
- m 1,5 suction pipe
- m 1,5 delivery pipe

* Excepting execution 11 and 23

FM 050-30



FM 050-50





SR Series

Type FM

SOME STANDARDS EXECUTIONS FOR MECHANICAL DIAPHRAGM PUMPS

| EXECUT. | PUMPHEAD | DIAPHRAGM | VALVE SEATS | VALVE (ball) | VALVES GASKETS |
|-----------|----------|-----------|-------------|--------------|----------------|
| 11 | S.S. 316 | PTFE/NBR | S.S. 316 | S.S. 316 | FPM |
| 12 | PP/FRV | PTFE/NBR | PP/FRV | PYREX | FPM |
| 13 | PVC | PTFE/NBR | PVC | PYREX | FPM |
| 16 | PVC | PTFE/NBR | PVC | S.S. 316 | FPM |
| 23 | PVDF | PTFE/NBR | PVDF | PYREX | FPM |

FPM = fluoroelastomer S.S. 316 = stainless steel 316 PP/FRV = polypropylene + glass fiber
Difference executions on request

Glossary and numbering system to identify pumps type

| FM | 050N | 50 / | F | 11 | DV |
|--|---------------|-----------------------------|---|--|------------------------------|
| 1ST group | 2nd group | 3rd group | 4th group | 5th group | 6th group |
| "FM" series Mechanical Diaphragm Dosing Pump | Stroke length | Diaphragm diameter in mm | Reduction ratio group (N° of strokes/min F(1/24) B (1/12) | Materials in contact with the fluid | Not standard-special code |

In case of pumps supplied without motor add: W/M

GENERAL OVERALL DIMENSIONS

| | 050-30 | 050-50 | 050-50 |
|-----------------|---------------|---------------|---------------|
| Exec. 11 | | | |
| A | 255 | 220 | 220 |
| B | 128 | 142 | 135 |
| C | 125 | 100 | 100 |
| D | 1/2" G.m. AB3 | 1/2" G.m. AB5 | 1/2" G.m. AB8 |
| Exec. 12 | | | |
| A | - | 220 | - |
| B | - | 152 | - |
| C | - | 100 | - |
| D | - | 1/2" G.m. AB5 | - |
| Exec. 13 | | | |
| A | 256 | 225 | 230 |
| B | 129 | 152 | 199 |
| C | 125 | 103 | 105 |
| D | 1/2" G.m. AB3 | 1/2" G.m. AB5 | 1/2" G.m. AB8 |

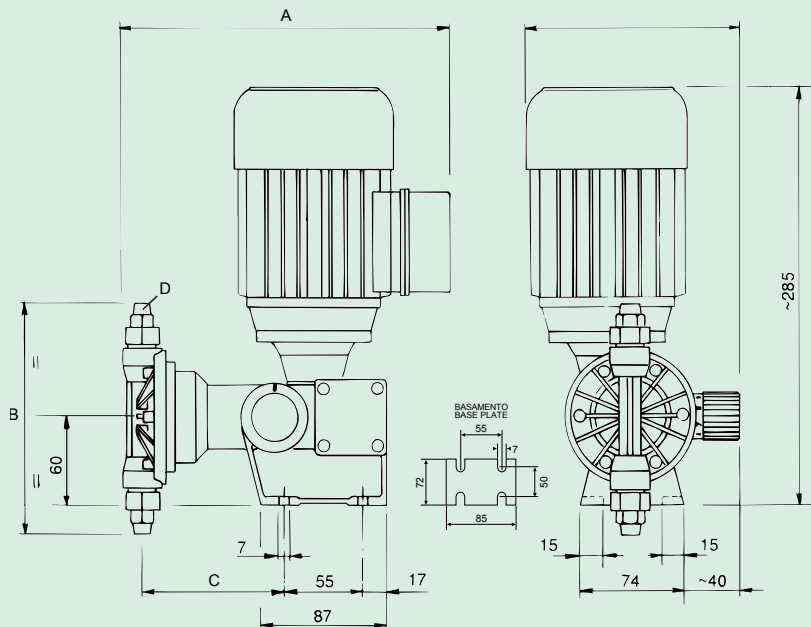

General dimensional quote are indicative and adverted to the maximum acceptable pump dimension

Spring Return Mechanical Diaphragm Dosing Pumps



Type FM 050 30

TECHNICAL CHARACTERISTICS

| Pump type | Reducer Ratio | | Capacity (*2) | | | | Max Press. (*3) Kg/cm2 | Connections (*4) | Motor Features | ø mm Diaphrag. | Stroke Length | Net Weights (*5) | | |
|-----------|---------------|----------|---------------|-------|-------|-------|---------------------------|------------------|----------------|--|---------------|-------------------|-------------------|--------|
| | (*1) | SPM (*1) | | L/1' | | L/h | | | | | | SS 316 + PVC + PP | SS 316 + PVC + PP | SS 316 |
| | | 50 Hz | 60 Hz | 50 Hz | 60 Hz | 50 Hz | 60 Hz | | | | | | | |
| FM 050-30 | H | 41 | 50 | 0,075 | 0,090 | 4,5 | 5,4 | 10 | 1/2" G.m. | Kw 0.09 3 Ph ~1400 rpm or Kw 0.09 1 Ph ~1400 rpm | 30 | 5 | 5,5 | 4,5 |
| | F | 58 | 70 | 0,116 | 0,140 | 7 | 8,4 | | | | | | | |
| | D | 82 | 98 | 0,158 | 0,190 | 9,5 | 11,4 | | | | | | | |
| | B | 116 | | 0,233 | | 14 | | | | | | | | |

Type FM 050 50

TECHNICAL CHARACTERISTICS

| Pump type | Reducer Ratio | | Capacity (*2) | | | | Max Press. (*3) Kg/cm2 | Connections (*4) | Motor Features | ø mm Diaphrag. | Stroke Length | Net Weights (*5) | | |
|-----------|---------------|----------|---------------|-------|-------|-------|---------------------------|------------------|----------------|--|---------------|-------------------|-------------------|--------|
| | (*1) | SPM (*1) | | L/1' | | L/h | | | | | | SS 316 + PVC + PP | SS 316 + PVC + PP | SS 316 |
| | | 50 Hz | 60 Hz | 50 Hz | 60 Hz | 50 Hz | 60 Hz | | | | | | | |
| FM 050-50 | H | 41 | 50 | 0,283 | 0,340 | 17 | 20,4 | 5 | 1/2" G.m. | Kw 0.09 3 Ph ~1400 rpm or Kw 0.09 1 Ph ~1400 rpm | 50 | 5 | 5,5 | 4,5 |
| | F | 58 | 70 | 0,383 | 0,460 | 23 | 27,6 | | | | | | | |
| | D | 82 | 98 | 0,566 | 0,680 | 34 | 40,8 | | | | | | | |
| | B | 116 | | 0,783 | | 47 | | | | | | | | |

(*1) Piston's strokes number during 1 minute with 4 poles installed motor (~1400 rpm 1')

H = Reducer ratio 1 : 34 = 41 strokes at 50 Hz / 50 strokes at 60 Hz

F = Reducer ratio 1 : 24 = 58 strokes at 50 Hz / 70 strokes at 60 Hz

D = Reducer ratio 1 : 17 = 82 strokes at 50 Hz / 98 strokes at 60 Hz

B = Reducer ratio 1 : 12 = 116 strokes at 50 Hz / not suitable

(*2) The indicated capacity value is subject to changes due to the working pressure, the dosed liquid, the viscosity and the installation asset.

(*3) The weight is approximate and is the value of the pump fitted with a totally enclosed fan-cooled outdoor motor.

(*4) The pumps are equipped with the following accessories: injection valve - mt.1,5 suction pipe - mt.1,5 delivery pipe - foot valve strainer - packing.



Accessories



Safety relief valves

| Type | Pump capacity | Connections |
|-------------|-----------------|--------------|
| TS-10 | 200 l/h | 3/8" or 1/2" |
| TS-13 | 400 l/h | 1/2" G.F |
| TS-21 | 1000 l/h | 1" G.F |
| Body | PVC or S.S. 316 | |

* S.S. 316 Relief - Safety valve setting pressure: max 40 kg/cm² (588 Psi) higher pressures are available on request.
 PVC Relief safety valve setting pressure: max 10 kg/cm² (145 Psi).
 For higher setting pressures consult our technical dept.



Pulsation dampeners

Type: HSTX
 Body in S.S.316, composed of two parts assembled by a special housing that under dynamic pressures tends to close itself. Diaphragms are compatible to the liquid used. Built in accordance with ASME VIII° Div. 1 rules.



Type: HSTPVC
 Body in PVC, composed of two parts assembled by a special housing that under hydraulic pressures tends to close itself. Maximum temperature: + 50 °C. Diaphragms are compatible with the process liquid.

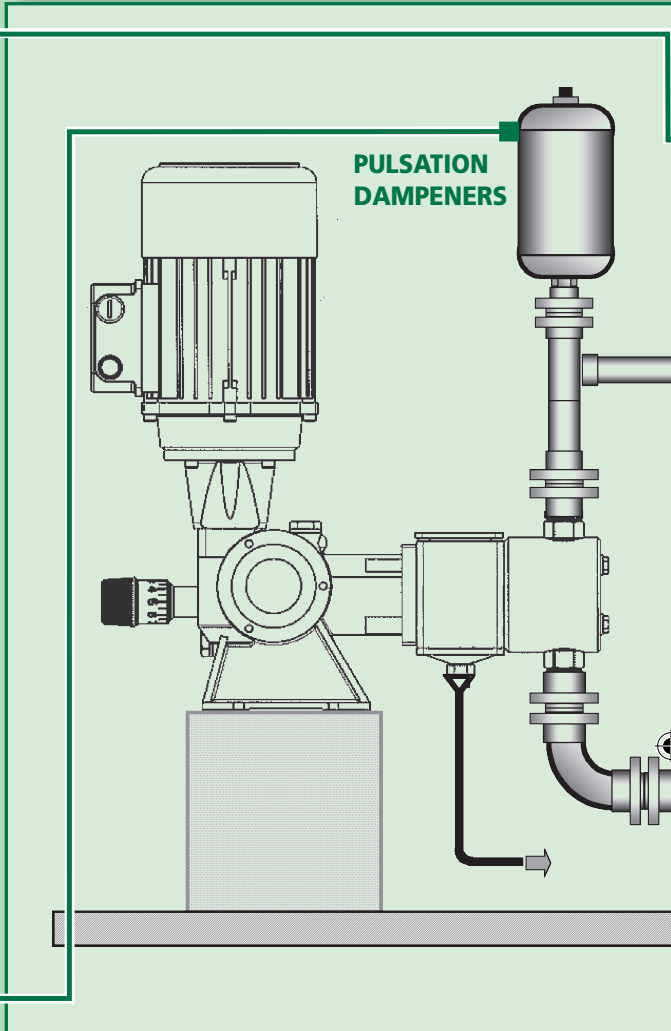

Each metering pump can be supplied with accessories in order to improve the operation and accuracy of the units. The benefits of fluid control assure

- Increase efficiency and pump life
- Decrease maintenance and operation costs

The control of fluid dynamics is essential to ensure efficient and safe use of process systems. Uncontrolled fluid in motion can physically destroy. A pumping system including the pumping, valves, meters, back pressure valves, inline instrumentation and equipment.

1.- FILTERS

We suggest to install filters (on the suction pipe) to keep back impurities that can be presented on liquid to be dosed or coming from pipeline system. The use of filters assures a trouble-free dosing.

2.- SAFETY VALVES

Safety valves are designed to protect the pump and chemical feed system from over pressure damage caused by defective equipment or a blockage in the chemical feed line.

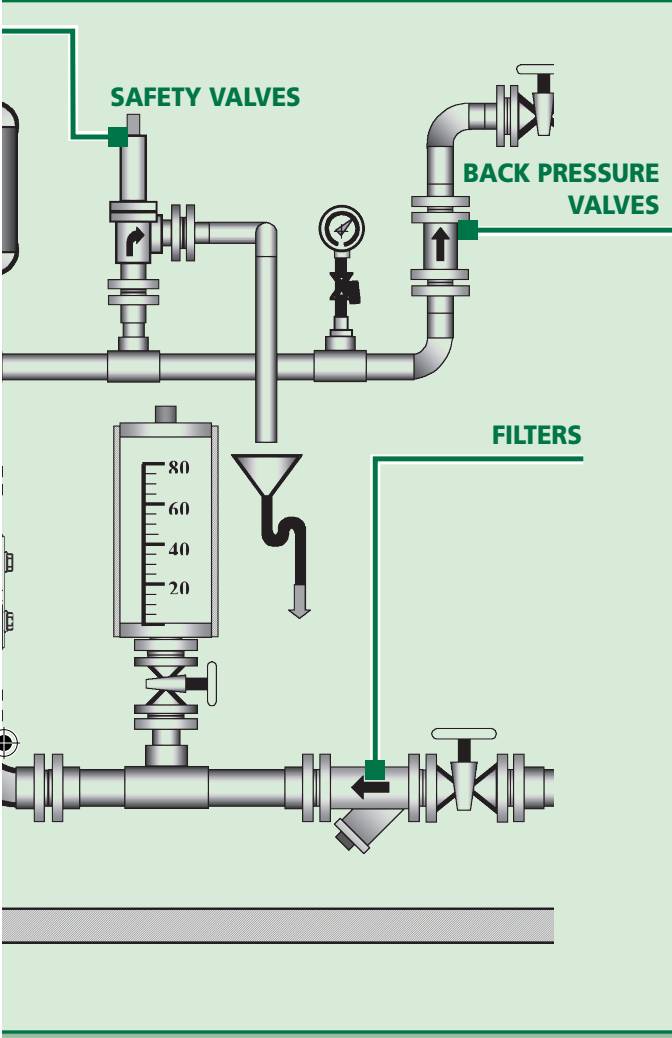

Relief valves

| Type | Pump Capacity | Connections |
|------------------|-----------------|-------------|
| VSCS-6 | 90 l/h | 1/2" G.F |
| VSCS-10 | 230 l/h | 1/2" G.F |
| VSCS-14 | 420 l/h | 3/4" G.F |
| VSCS-22 | 1050 l/h | 1" G.F |
| Body | PVC or S.S. 316 | |
| Diaphragm | PTFE/NBR | |

* Relief valve setting pressure: 0÷20 kg/cm²
 the max value change due the size and materials
 G.F.= Cylindrical, Female



Back pressure valves

| Type | Pump Capacity | Connections |
|------------------|-----------------|-------------|
| VSCC-6 | 90 l/h | 1/2" G.F |
| VSCC-10 | 230 l/h | 1/2" G.F |
| VSCC-14 | 420 l/h | 3/4" G.F |
| VSCC-22 | 1050 l/h | 1" G.F |
| Body | PVC or S.S. 316 | |
| Diaphragm | PTFE/NBR | |

* Back pressure valve setting pressure:
 0÷2.5 kg/cm²
 G.F.= Cylindrical, Female



3.- BACK PRESSURE VALVES

Back pressure valves apply positive discharge pressure to a metering pump system to prevent siphoning and eliminate varying downstream pressure.

4.- PULSATION DAMPENER

Metering pumps have a pulsating flow. Both spring return plunger dosing pumps and quick closing valves start and stop fluids that are in motion. Spring return plunger dosing pumps derive their pumping action by capturing a given amount of fluid in a chamber and pushing it out the pump's discharge.

Each pump cycle includes a suction stroke during the fluid flow is stopped. This pumping action produces an acceleration/deceleration of the fluid, creating units of uncontrolled energy, resulting in PULSATION, observed as pressure spikes.

- Pulsation dampener is required for two reasons:
- Two reduce high, non- permissible pressure fluctuations.
 - To create a nearly continuous flow.

Polyethylene tanks

suitable to be fitted with metering pump on its top





Our range of production also includes:

SR Spring Return Series:

Piston dosing pumps "A" and "AP-A" types
Hydraulic diaphragm dosing pumps "B", "BR" and "SD" series
Mechanical Diaphragm dosing pumps "D" series

PDP Positive Displacement Series:

Piston dosing pumps "AI" and "AP-AI" types
Interposed Fluid Diaphragm Dosing Pumps "BI" and "SDI"

SDP series:

Solenoid dosing pumps "S" type
Solenoid dosing pumps "GA" type

H series:

Automatic plants for preparation of polyelectrolyte "HA", "HB", "HE" and "HA-P" types

EM series:

Electric mixers "DAM", "DMT", "DEM", "DRV", "DRC" and "DVL" types



HEAD OFFICE

Via G. Carducci 141
20093 Cologno Monzese (MI) Italy
Tel.: +39 02 27301324
Fax: +39 02 26700883
e-mail: info@doseuro.com
www.doseuro.com

DOSEURO (UK) LTD.

Unit 8, East Road Industrial Estate
Sleaford, Lincolnshire NG34 7EH
Tel.: +44 1529 300045
Fax: +44 1529 410967
e-mail: enquiries@doseuro.co.uk
www.doseuro.co.uk

DOSEURO®
The right dosing choice