



Magnetic Float Level Transmitter

INTRODUCTION

PRINCIPLE

The "Magnet Float Level Transmitter" is composed of the float and sensing rod (shown as below). As the float raised or lowered by liquid level, the sensing rod will have a resistance output, which is directly proportional to the liquid level. Also, the float level indicator can be equipped with the TAB-2100 (please see page 3) to produce a 0/4~20mA signal. In addition, we can use with PB series bargraphic display scaling panel meter for level control and display. Anyway, "Magnet Float Level Indicator" is a great benefit to all kinds of industries with its easy working principle and reliability.

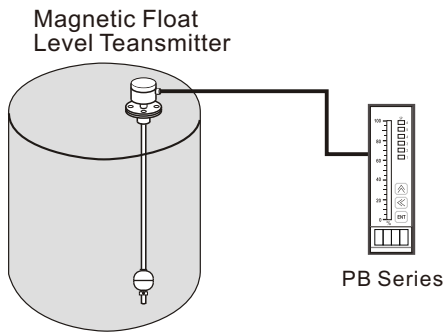

FEATURES

- Every sensing element is protected by a plastic package, safety in use and transport. (as fig. 1)
- High performance and reliability of electric circuit modular designed (as fig.2).
- Lower installation costs, less maintenance, reduced personnel training, and decreased plant shock down time.
- Explosion Proof
- Marine Proof, ABS, DNV, BV, LR, GL

APPLICATIONS

Applied for waste water treatment turn-key facility, electric power plant, shipping vessel, hydraulic facility, chemical industrial equipment, petrochemical industry and hot coal boiler. e.g. diesel engine generator, motor oil meter, oil material storage tank.

SCHEMATIC DIAGRAM OF THE PRINCIPLES

1. Sensing Rod
2. Float
3. Transmitter
4. Display Unit

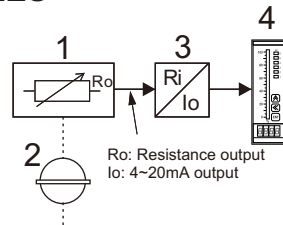

CONSTRUCTION

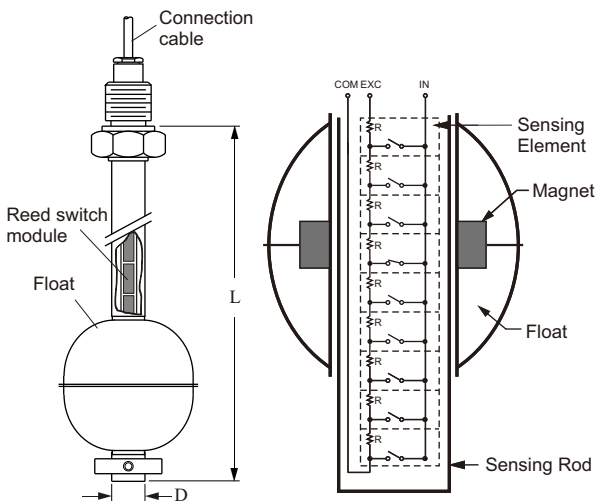

Sensing Element Size

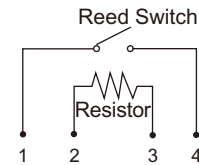
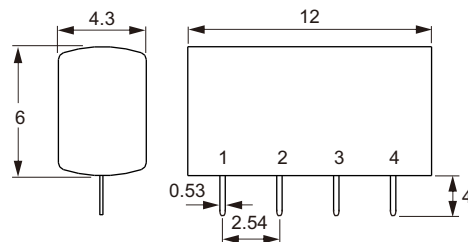

Fig.2

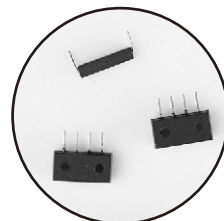

Fig.1
Sensing Element

HOUSING DIMENSION

B
 Material : Aluminum
 Enclosure : IP65
 Max.Temp.: -20°C ~200°C

C
 Material : P.P.+Fiber
 Enclosure : IP65
 Max.Temp.: -20°C ~80°C

D

Material : Aluminum
 Enclosure : IP65
 Max.Temp.: -20°C ~200°C

G

Material : PC
 Enclosure : IP65
 Max.Temp.: -20°C ~80°C

K Explosion-proof

Material : Aluminum
 Enclosure : CESI 03 ATEX 108
 ATEX II 2G EEx d IIC T6
 Max.Temp.: -20°C ~100°C

N

Material : SUS316
 Enclosure : IP65
 Max.Temp.: -20°C ~200°C

X

Material : Aluminum
 Enclosure : IP65
 Max.Temp.: -20°C ~100°C

● FLOAT SPECIFICATION

Dimension	Type	AxBxC(mm)	S.G.	Max. Pressure (kg/cm ²)	Material	Max. Temp. (°C)	Approx. Weight (g)
	S3	45x55x15	0.65	12	SUS 316	200°C	37.6
	S6	75x108x19	0.5	10	SUS 304	200°C	165
	S4	52x52x15	0.55	30	SUS 316	200°C	33.4
	S5	75x73x19	0.55	30	SUS 304	200°C	102.4
	S8	100x100x20	0.5	15	SUS 304	200°C	249.7
	S9	150x150x30	0.45	15	SUS 304	200°C	534
	P3	48x45x18.5	0.6	5	PP	80°C	35.5
	F4	48x62x18	0.75	5	PVDF	120°C	65.3

TRANSDUCER

MODEL: TAB-2110 Transducer

Power Supply : 12~36Vdc
 Output Current : Loop power 4~20mA
 Load Resistance : $RL(\text{Max})=50(\text{Vs}-8)$
 Ambient Temperature : -40~80°C
 Ambient Humidity : 0~80% RH
 Accuracy : $\pm 0.1\%(25^\circ\text{C})$
 Temperature Effect : 0.01%F.S./°C
 Adjustment Range : Span Ajustment 20% FS
 Zero Ajustment 5% FS

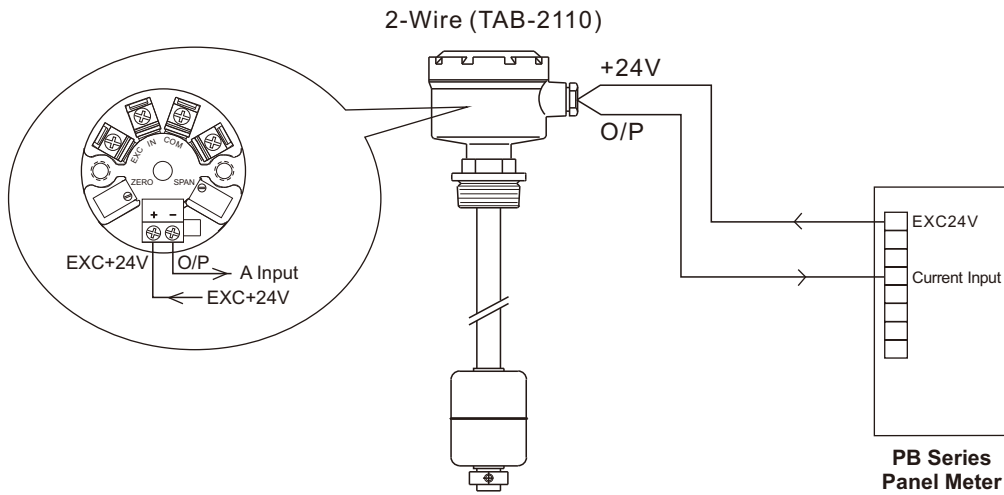
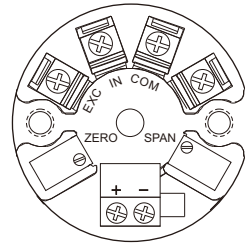

ECONOMICAL

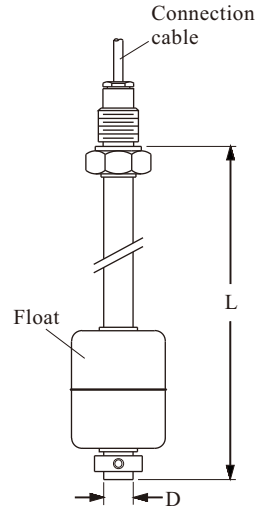
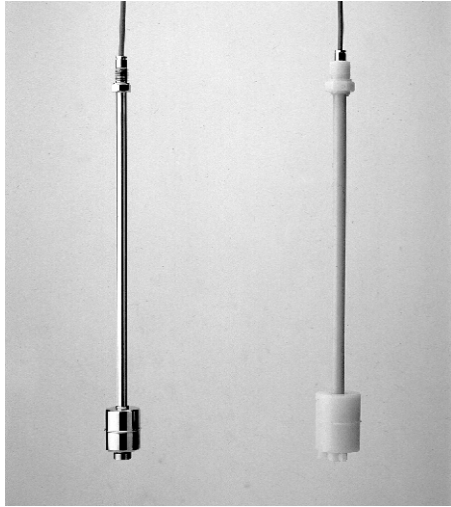

● SPECIFICATION

Connection Cable: Silicon cable 3C × 1M
Output: 3-wire resistance output

Operating Temp.: PP tube -10 °C ~ 80 °C
 PVDF tube -20 °C ~ 120 °C
 SUS tube -20 °C ~ 120 °C

Order No.	Connecting	Tube size & Material (D)	Float type & Material	Suitable S.G.	Measuring Range
FG□-AR4	3/8"PF	φ14 SUS 304 SUS 316	S3: φ45x55 SUS 316 S4: φ52x52 SUS 316	>0.65 >0.55	FGA...Max.6M FGB...Max.6M
FG□-AR7	3/8"PF	φ17.2 SUS 304	S5: φ75x73 SUS 304 S6: φ75x108	>0.55 >0.5	FGA...Max.6M FGB...Max.6M
FGB-CR5P3	3/4"PF	φ17.2 PP	P3: φ48x45 PP	>0.6	FGB...Max.6M
FGB-CR6F4	3/4"PF	φ16 PVDF	F4: φ48x62 PVDF	>0.75	FGB...Max.6M

MODEL : FG □ - □ □ □ □ □ □ □ □

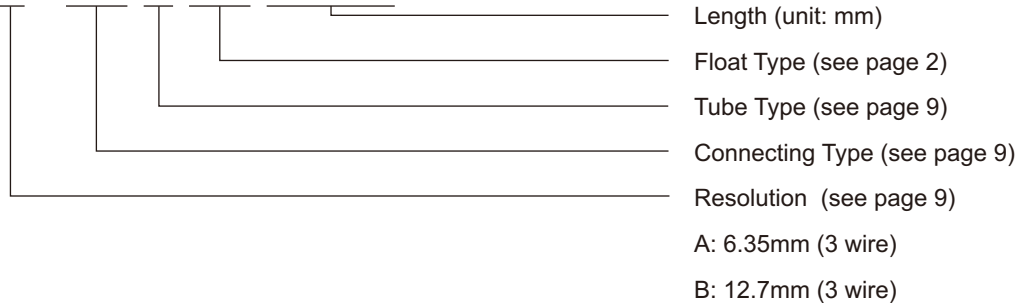

STANDARD

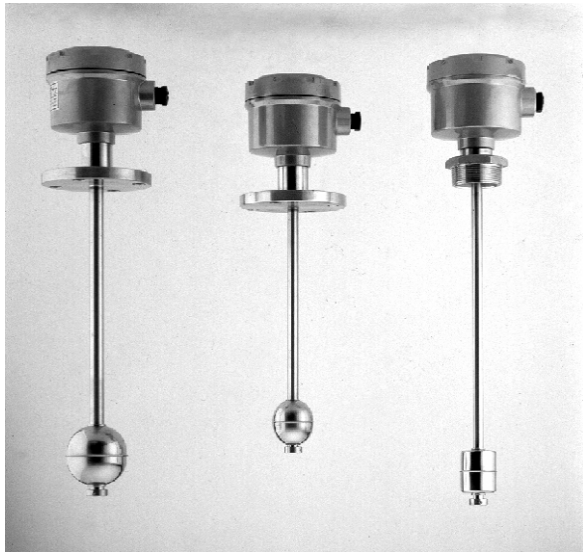

★ B type housing, dimension see page 2.

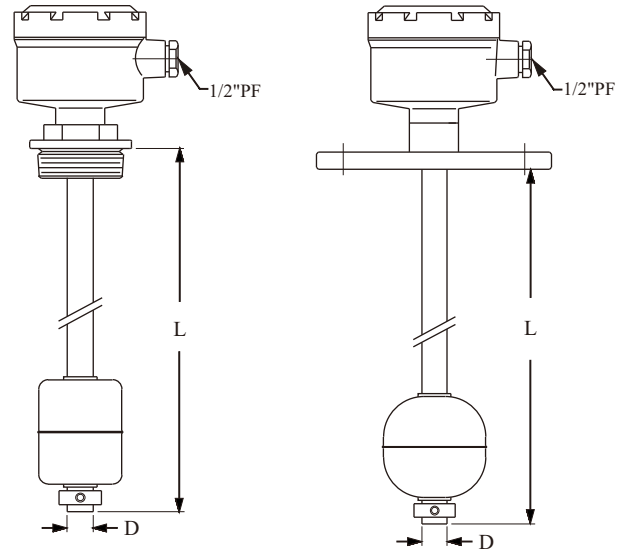

● SPECIFICATION

Terminal Housing: Aluminum, IP65
Output: 4~20mA, 2-wire
Total resistance value: 1MΩ (Max.)

Operating Temp.: -20 °C ~ 120 °C
Ambient Temp.: 0~70 °C

Order No.	Connecting	Tube size & Material (D)	Float type & Material	Suitable S.G.	Measuring Range
FG□BFQ4	2"NPT	φ14 SUS 316 SUS 304	S3: φ45x55 SUS 316 S4: φ52x52 SUS 316	>0.65 >0.55	FGC/D...Max.6M
FG□BGN4	2-1/2"x10kg/cm ²	φ14 SUS 316 SUS 304	S3: φ45x55 SUS 316 S4: φ52x52 SUS 316	>0.65 >0.55	FGC/D...Max.6M
FGDBHN7	3"x10kg/cm ²	φ17.2 SUS 304	S5: φ75x73 SUS 304 S6: φ75x108 SUS 304	>0.55 >0.5	FGD...Max.6M
FGDBIQ7	4"NPT	φ17.2 SUS 304	S8: φ100x100 SUS 304	>0.5	FGD...Max.6M
FGDBKN8 FGDBKN9	6"x10kg/cm ²	φ21.7 φ27.2 SUS 304	S9: φ150x150 SUS 304	>0.45	FGD...Max.12M

MODEL : FG□ B □ □ □ □ □ □ □ □

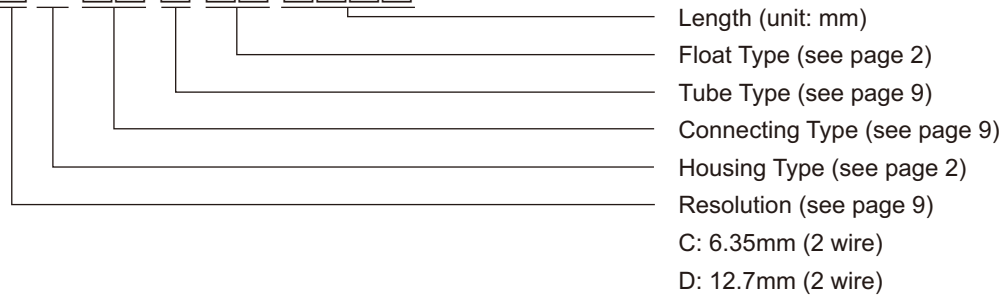

ANTI-ACID / ALKALINE



★ C type housing, dimension see page 2.

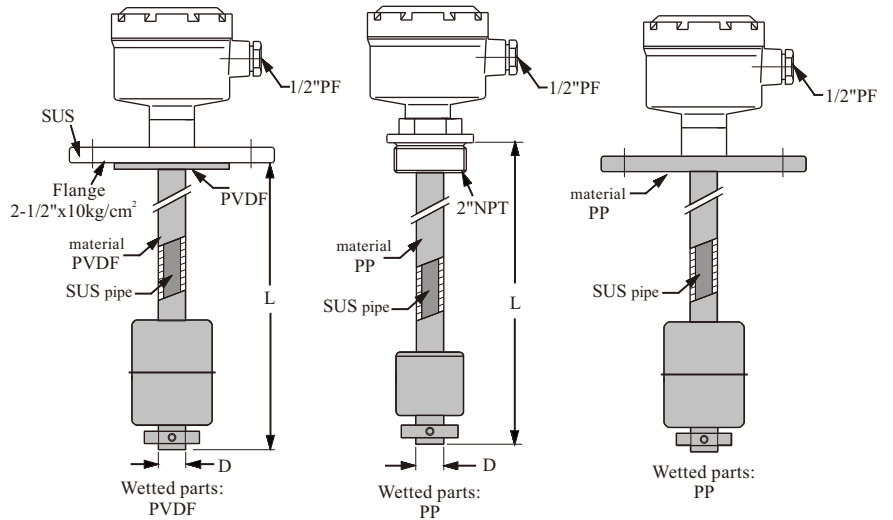

● SPECIFICATION

Terminal Housing: PP +Fiber, IP65
Output: 4~20mA, 2-wire
Ambient Temp.: 0~70 °C

Operating Temp.: PP jacket tube -10 °C ~ 80 °C
 PVDF jacket tube -20 °C ~ 120 °C
Total resistance value: 1MΩ (Max.)

Order No.	Connecting	Tube size & Material (D)	Float type & Material	Suitable S.G.	Measuring Range
FGDCFQ5P3	2"NPT	φ17.2 PP	P3: φ48x45 PP	>0.55	FGD...Max.6M
FGDCFQ6F4	2"NPT	φ16 PVDF	F4: φ48x62 PVDF	>0.75	FGD...Max.6M
FGDCGN5P3	2-1/2"x10kg/cm ²	φ17.2 PP	P3: φ48x45 PP	>0.6	FGD...Max.6M
FGDCGN6F4	2-1/2"x10kg/cm ²	φ16 PVDF	F4: φ48x62 PVDF	>0.75	FGD...Max.6M

Every unit is protected by PP or PVDF flange to prevent the sensing rod from chemical corrosion.

MODEL : FG DC



★K type ATEX Explosion proof Enclosure can be selected, dimension see page 2.

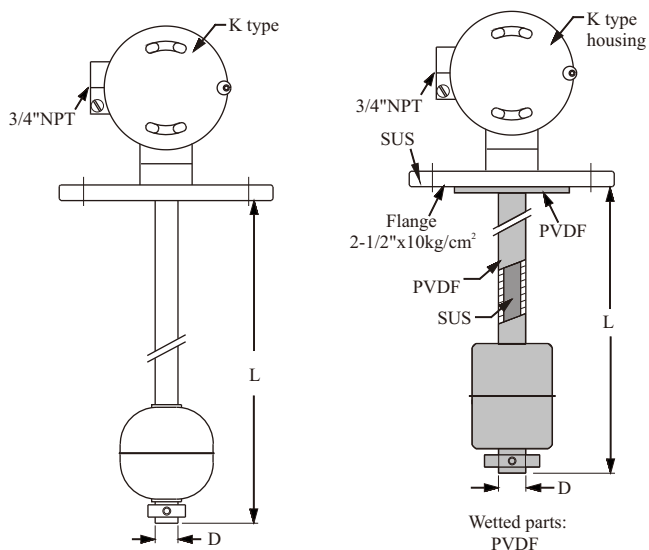

● SPECIFICATION

Terminal Housing: K type --- Aluminum, ATEX EEx d IIC T6 **Operating Temp.:** PP tube -10°C ~ 80°C
Output: 4~20mA, 2-wire PVDF tube -20°C ~ 120°C
Ambient Temp.: 0~70 °C SUS tube -20°C ~ 120°C
Total resistance value: 1MΩ (Max.)

Order No.	Connecting	Tube size & Material (D)	Float type & Material	Suitable S.G.	Measuring Range
FG□KFQ4	2"NPT	φ14 SUS 304	S4: φ52x52 SUS 316	>0.55	FGA/B...Max.6M FGC/D...Max.6M
FG□KGN4	2-1/2"x10kg/cm ²	φ14 SUS 304	S4: φ52x52 SUS 316	>0.55	FGA/B...Max.6M FGC/D...Max.6M
FGDKHN7	3"x10kg/cm ²	φ17.2 SUS 304	S6: φ75x108 SUS 304	>0.5	FGD...Max.6M
FGDKIQ4	4"NPT	φ17.2 SUS 304	S8: φ100x100 SUS 304	>0.5	FGD...Max.6M
FGDKFQ5P3	2"NPT	φ17.2 PP	P3: φ48x45 PP	>0.6	FGD...Max.6M
FGDKFQ6F4	2"NPT	φ16 PVDF	F4: φ48x62 PVDF	>0.75	FGD...Max.6M
FGDKGN5P3	2-1/2"x10kg/cm ²	φ17.2 PP	P3: φ48x45 PP	>0.6	FGD...Max.6M
FGDKGN6F4	2-1/2"x10kg/cm ²	φ16 PVDF	F4: φ48x62 PVDF	>0.75	FGD...Max.6M

MODEL : FG □ □ □ □ □ □ □ □ □ □

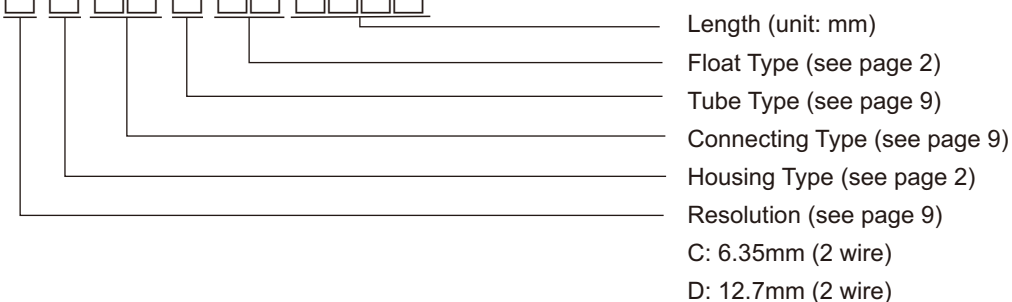

MULTI-FUNCTION



- Double insulations to prevent damage on PCB by moisture.
- Data can be displayed by LCD panel on transmitter.
- Power supply: 12~36 Vdc
- Photo Coupler * 2
- Reed module designed with protective housing to ensure stability and to prevent damage from transportation, installation and operation.
- Accuracy is not affected by modification of temperature, pressure.
- Circuit design is stable and reliable.



● SPECIFICATION

Terminal Housing: Aluminum/PP+Fiber (IP65)

Measured Total Resistance: 1K~2MΩ

Output: 2 Wire 4~20mA Output

Ambient Temp.: -40~80°C

Operation Temp.:

P.P.: -10°C~80°C

PVDF: -20°C~120°C

Power Supply: Loop Power 12~36Vdc

Output Current: 4~20mA

Output Linear Range: 3.8~21.5mA

Output Latch: 3.5mA, 22mA (Please reboot to delatch)

Upper Output: 22mA

Lower Output: 3.5mA

LCD Display: -1999~9999

Load Resistance: $RL = (Vs - 12) * 50\Omega$

Environment Humidity: 0~80% RH

Accuracy: 0.1%F.S. (25°C)

Temperature Coefficient: $\pm 0.01\% \text{ FS}/^\circ\text{C}$

Alarm Output:

Mode: Photo coupler x 2

Contact Capacity: 8~30Vdc (50mA)

Operation Model: Alarm: Process High Alarm/
Process Low Alarm

FG□F Series Standard Model

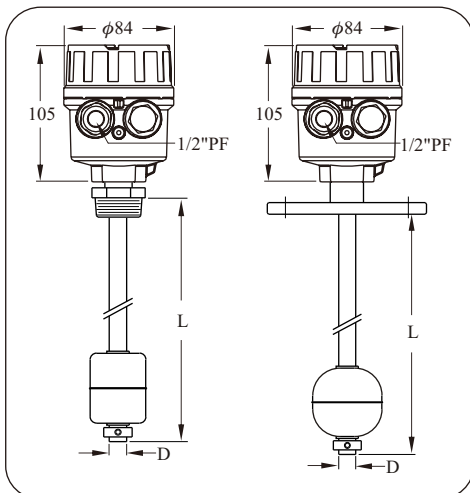

FG□F Series Anti-Acid/Alkaline Model

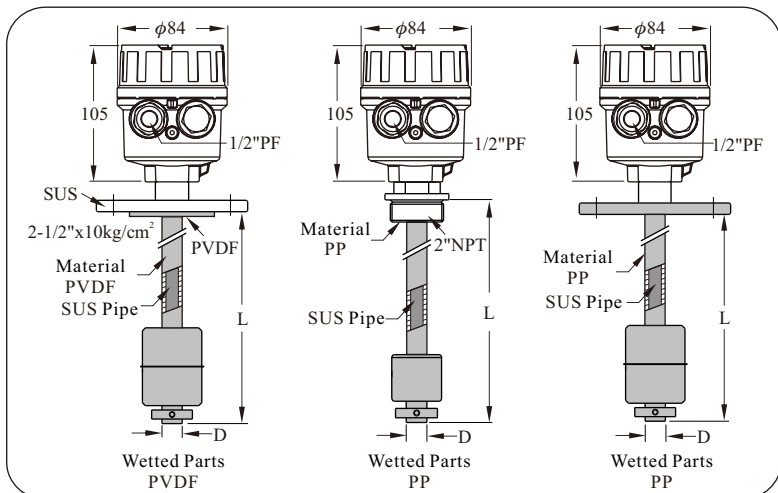

ORDER INFORMATION

FG **D** **C** **FQ** **6** **F1** **1500** **(P)**

RESOLUTION

- | | |
|--------------------|----------------------------|
| A: 6.35mm (3-wire) | E: 6.35mm (Multi-Function) |
| B: 12.7mm (3-wire) | F: 12.7mm (Multi-Function) |
| C: 6.35mm (2-wire) | G: 6.35mm |
| D: 12.7mm (2-wire) | (Multi-Function+HART) |
| | H: 12.7mm |
| S: Others | (Multi-Function+HART) |

TERMINAL HOUSING (see page 2)

- | | |
|-------------------------------|-----------|
| B: Aluminum (IP65) | - : None |
| C: P.P (IP65) | S: Others |
| D: Aluminum (Ex d IIC T3~T6) | |
| E: AL. (Small space) IP65 | |
| G: PC (IP65) | |
| K: Aluminum (EEx d IIC T3~T6) | |
| N: SUS (Ex d IIC T3~T6) | |
| F: Aluminum | |

CONNECTING TYPE

Dimension		Specification	
A: 3/8" (10A)	H: 3" (80A)	M: 5 Kg/cm ²	U : NPT
B: 1/2" (15A)	I : 4" (100A)	N:10 Kg/cm ²	V : GAS
C: 3/4" (20A)	J : 5" (125A)	O: 150 Lbs	S : Others
D: 1" (25A)	K: 6" (150A)	P: 300 Lbs	
E: 1 1/2" (40A)	4 : 7" (175A)	Q: PT	
F: 2" (50A)	5 : 8" (200A)	R: PF(G)	
G: 2 1/2" (65A)		T: BSP	

※ Tri-Clamp 1-1/2"=ES; 2"=FS

TUBE TYPE & MATERIAL

- | | |
|---------------------------------------|---------------------------------------|
| 0: ϕ 12.7 (SUS304) | C: ϕ 12.7 (SUS316) |
| Only available for resolution 12.7mm. | Only available for resolution 12.7mm. |
| 4: ϕ 14 (SUS304) | B: ϕ 14 (SUS316) |
| 5: ϕ 17.2 (P.P.) | D: ϕ 17.2 (SUS316) |
| 6: ϕ 16 (PVDF) | E: ϕ 21.7 (SUS316) |
| 7: ϕ 17.2 (SUS304) | F: ϕ 27.2 (SUS316) |
| 8: ϕ 21.7 (SUS304) | |
| 9: ϕ 27.2 (SUS304) | |

FLOAT TYPE (see page 2)

Material	Type					
Plastic	P3	F4				
SUS	S3	S4	S5	S6	S8	S9

- : None

LENGTH (UNIT : mm)

- 0500**: 500mm up ※ 500mm per Unit
1000: 501~1000mm
1500: 1001~1500mm

⋮

PIPE SHIELD

- ★ Tolerance of the total product length is ± 5 mm.
- ★ Characteristics, specifications and dimensions are subject to change without notice.
- ★ Please contact us for further informations.

ENCLOSURE EXPLOSION PROOF

★ D or N type housing can be selected.

NEPSI PROOF No. GYJ06231 Ex d IIC T3~T6
 PTB PROOF No. 05 ATEX 1028 $\text{Ex II 2G EEx d IIB T3~T6}$
 $\text{Ex II 2D IP65 T3~T6}$

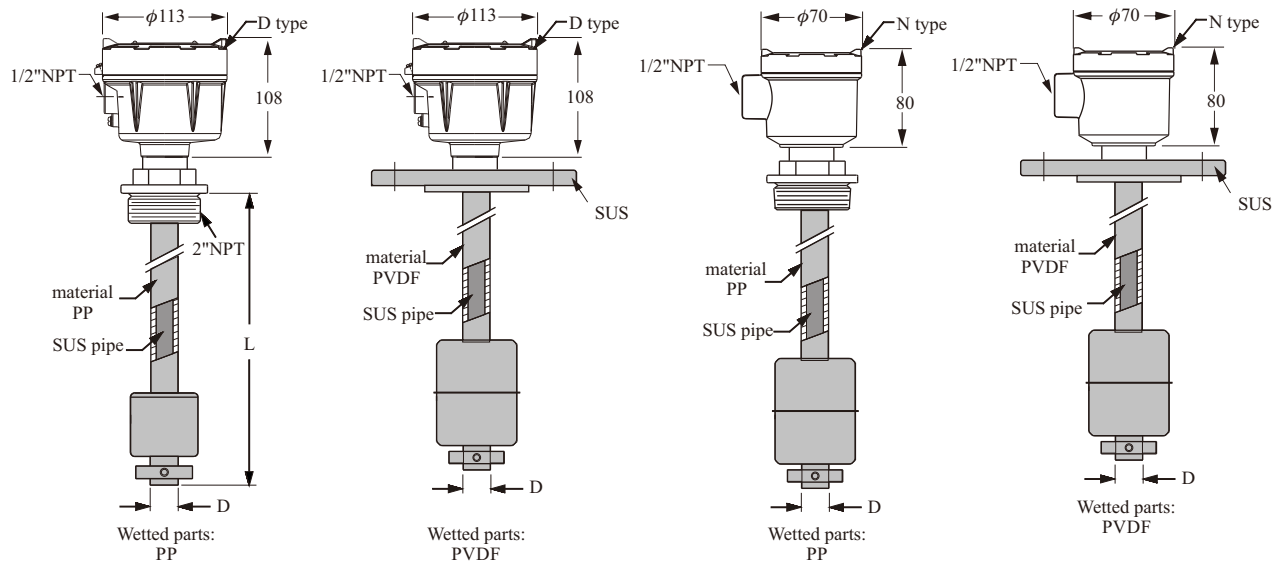

● SPECIFICATION

Terminal Housing: D type --- Aluminum, Ex d IIB T3~T6
 N type --- SUS, Ex d IIC T3~T6

Total Resistance Value.: 1MΩ (Max.)

Operation Temp.: PP tube -10 °C ~ 80 °C
 PVDF tube -20 °C ~ 120 °C

Output: 4~20mA, 2-wire
Ambient Temp.: 0~70 °C

ORDER NO. FG7 MODEL NO. RL7	Connecting	Tube size (D) & Material	Float type & Material	Suitable S.G.	Measuring Range
RL7□DFQ4	2"NPT	φ14 SUS 316	S3: φ45x55 SUS 316	>0.65	RL7...Max.3M
RL7□DGN4	2-1/2"x10kg/cm ²	φ14 SUS 316	S3: φ45x55 SUS 316	>0.65	RL7...Max.3M
RL7DDHN7	3"x10kg/cm ²	φ17.2 SUS 304	S5: φ75x73 SUS 304	>0.55	RL7...Max.6M
RL7DDIQ4	4"NPT	φ17.2 SUS 304	S8: φ100x100 SUS 304	>0.5	RL7...Max.6M
RL7DDKN8 RL7DDKN9 RL7DDKN8 RL7DDKN9	6"x10kg/cm ²	φ21.7 φ27.2 SUS 304	S9: φ150x150 SUS 304	>0.45	RL7...Max.6M
RL7DDFQ5P3	2"NPT	φ17.2 PP	P3: φ48x45 PP	>0.6	RL7...Max.6M
RL7DDFQ6F4	2"NPT	φ16 PVDF	F4: φ48x62 PVDF	>0.75	RL7...Max.6M
RL7DDGN5P3	2-1/2"x10kg/cm ²	φ17.2 PP	P3: φ48x45 PP	>0.6	RL7...Max.6M
RL7DDGN6F4	2-1/2"x10kg/cm ²	φ16 PVDF	F4: φ48x62 PVDF	>0.75	RL7...Max.6M

ORDER NO.: FG7 □ □ □ □ □ □ □ □ □ □
 MODEL NO.: RL7 □ □ □ □ □ □ □ □ □ □

- Length (unit: mm)
- Float Type (see page 2)
- Tube Type (see page 11)
- Connecting Type (see page 11)
- Housing Type (see page 2)
- Resolution (see page 11)
- C: 6.35mm (2 wire)
- D: 12.7mm (2 wire)

ORDER NAME INFORMATION

Order No. FG7 **D** **D** **FQ** **6** **F1** **1500** (L)
Model No. RL7 **D** **D** **FQ** **6** **F1** **1500** (L)

RESOLUTION

- A : 6.35mm (3-wire)
- B : 12.7mm (3-wire)
- C : 6.35mm (2-wire)
- D : 12.7mm (2-wire)

TERMINAL HOUSING (see page 2)

- D: AL (Ex d IIC T3~T6)
- N: SUS (Ex d IIC T3~T6)

CONNECTING TYPE

Dimension		Specification	
A: 3/8" (10A)	H: 3" (80A)	M: 5 Kg/cm ²	U: NPT
B: 1/2" (15A)	I: 4" (100A)	N: 10 Kg/cm ²	V: GAS
C: 3/4" (20A)	J: 5" (125A)	O: 150 Lbs	S: Others
D: 1" (25A)	K: 6" (150A)	P: 300 Lbs	
E: 1 1/2" (40A)	4: 7" (175A)	Q: PT	
F: 2" (50A)	5: 8" (200A)	R: PF(G)	
G: 2 1/2" (65A)		T: BSP	

TUBE TYPE & MATERIAL

- | | |
|---------------------------------------|---------------------------------------|
| 0: ϕ 12.7 (SUS) | C: f12.7 (SUS316) |
| Only available for resolution 12.7mm. | Only available for resolution 12.7mm. |
| 4: ϕ 14 (SUS) | B: f14 (SUS316) |
| 5: ϕ 17.2 (P.P.) | D: f17.2 (SUS316) |
| 6: ϕ 16 (PVDF) | E: f21.7 (SUS316) |
| 7: ϕ 17.2 (SUS) | F: f27.2 (SUS316) |
| 8: ϕ 21.7 (SUS) | |
| 9: ϕ 27.2 (SUS) | |

FLOAT TYPE (see page 2)

Material	Type					
	Plastic	P3	F4			
SUS	S3	S4	S5	S6	S8	S9

LENGTH (UNIT : mm)

- 0500: 500mm up
 - 1000: 501~1000mm
 - 1500: 1001~1500mm
 - ⋮
- ※ 500mm per Unit

TAG

- ★ Tolerance of the total product length is ± 5 mm.
- ★ Characteristics, specifications and dimensions are subject to change without notice.
- ★ Please contact us for further informations.

INSTALLATION

- ▶ The float level indicator should be mounted far away from liquid inlet. Any strong liquid fluctuation will produce error output signals.

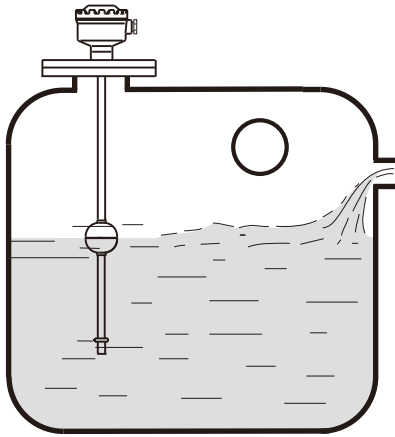

- ▶ It is requested a pipe shield or equivalent device to normalize the indicator actuation if the indicator is used with any agitator application.

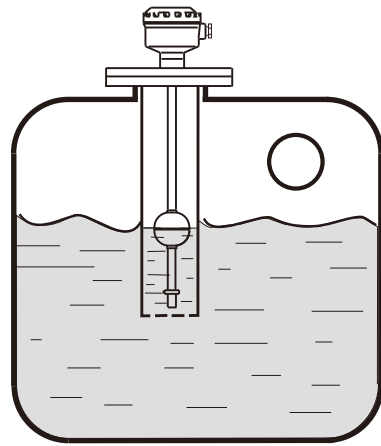

- ▶ It had better require an L type supporter, when the level indicator is mounted in concrete wall tank as figure below.

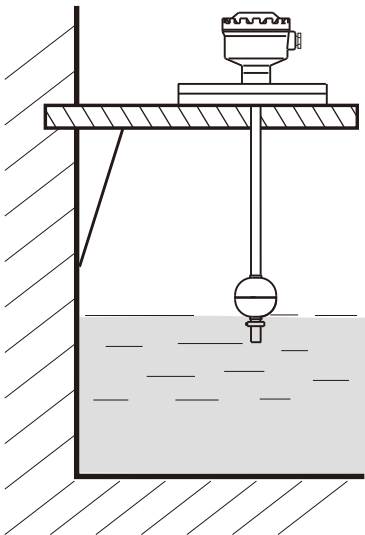

- ▶ It is recommended to select the standpipe with diameter(d) larger than the float ball for Installation process.

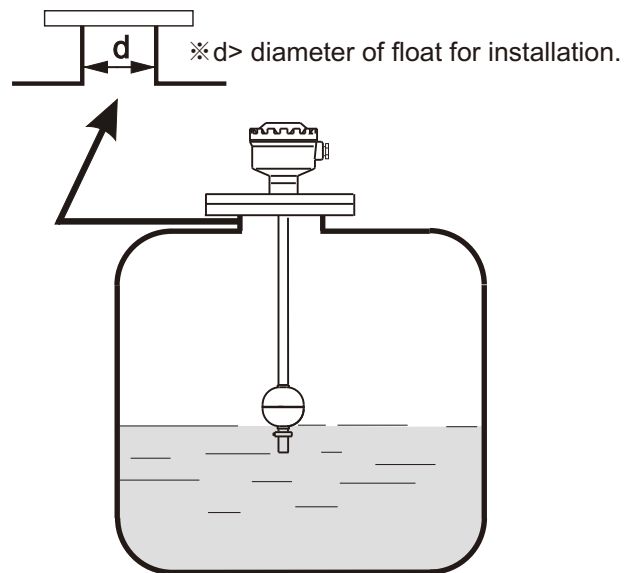

EXAMPLES-OF-TANK-MOUNTING

- [FC/FD] Mini Float/Magnetic Float Level Switch
- [FG] Magnetic Float Level Transmitter
- [FF] Side Mounting Float Switch
- [FA/FB] Cable Float Level Switch
- [SP] Thermal Dispersion Flow Switch
- [SF] Paddle Flow Switch
- [SD] Optical Level Switch
- [SE] Rotary Paddle Level Switch
- [SA] Capacitance Level Switch
- [EC] Pressure Level Transmitter
- [LR] Loop Power Indicator
- [SC] Vibrating Probe Level Switch
- [SC] Tuning Fork Level Switch
- [EB] RF-Capacitance Level Transmitter
- [SB] RF-Capacitance / Admittance Level Switch
- [EG] Magnetostrictive Level Transmitter
- [EF] By-Pass Level Transmitter
- [MEF] Mini By-Pass Level Transmitter
- [EA] Ultrasonic Level Transmitter
- [JFR] FMCW Radar Level Transmitter
- [EE] Electromechanical Level Measuring System
- [ED] Speed Monitor
- [SRT/SRS] Conveyor Belt Misalignment Switch & Safety Cable Pull Switch
- [PB/PM] Microprocessor Based Bargraphic Display Scaling Meter
- [BRD/AE] Valve and Controller for Dust Collector System
- [BAS/BAH/BVP] Air Hammer
- [BVK/BVR/BVT] Pneumatic Vibrator

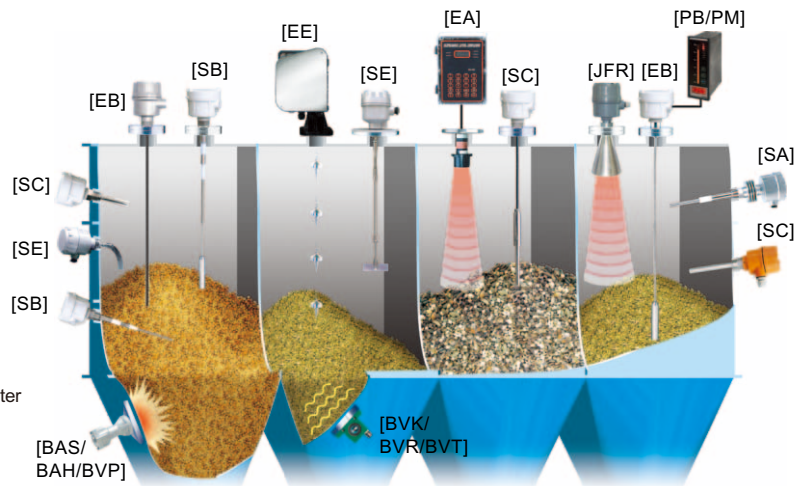
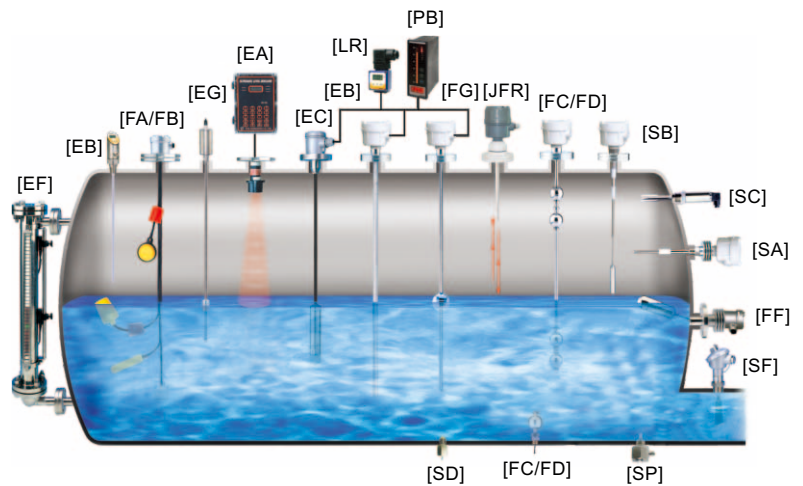

FineTek Co., Ltd.

No.16, Tzuchiang St., Tucheng Industrial Park, New Taipei City 236, Taiwan
 TEL: +886-2-2269-6789 FAX: +886-2-2268-6682
 Email: info@fine-tek.com http://www.fine-tek.com

Fine automation (Shanghai) Co., Ltd.

No.451 DuHui Rd, MinHang District, Shanghai, China 201109
 TEL: +86-21-6490-7260 FAX: +86-21-6490-7276
 Email: info.sh@fine-tek.com

FineTek Pte Ltd.

No. 11 Kaki Bukit Road 1, #04-01 Eunos
 Technolink 415939, Singapore
 TEL: +65-6452-6340 FAX: +65-6734-1878
 Email: info.sg@fine-tek.com

FineTeK GmbH

Frankfurter Str. 62, OG D-65428 Ruesselsehim, Germany
 TEL: +49-(0)6142-17608-0 FAX: +49-(0)6142-17608-20
 E-Mail: info@fine-tek.de



Distributor: