



The FLOWX3 F3.60M & F3.63M Insertion Magmeters are suitable to measure flowrate in both metal and thermoplastic pipelines. No moving mechanical parts and the high quality materials allow the measurement of liquids where suspended solids can be present or of abrasive liquids as long as they are conductive and homogeneous. The sensor can be assembled into the standard FLS fitting range so it is perfectly interchangeable with the paddlewheel sensors. The new design allows an accurate flow measurement over a wide dynamic range in pipe sizes from DN15 (0.5") to DN600 (24"). The F3.60M & F3.63 offer frequency output for use with FLS flow instrumentation and 4-20 mA output for long distance transmission and PLC connection.

Main Features

- No moving parts, no wear, maintenance free.
- High mechanical resistance.
- For DN15 (0.5") to DN600 (24") pipes.
- Flow Rate Range:
 - F3.60M: from 0.05 to 8 m/s (0.15 to 25 ft/s)
 - F3.63M: from 0.15 to 8 m/s (0.5 to 25 ft/s).
- Accurate measurement of dirty liquids.
- Blind 4-20 mA or frequency output.
- Bi-directional flow measurement (F3.60M).
- Low pressure drop.
- Special versions for salt-water applications (high concentrations of chlorides like sea water) and for high temperature conditions.

Applications

- Water and waste water treatment.
- Raw water intake.
- Industrial water distribution.
- Textile industry.
- Pools, spas and aquariums.
- HVAC.
- Processing and manufacturing industry.
- Sea water applications.

Operating Principle

If an electrical conductor is caused to move in a magnetic field, such movement induces a voltage in the conductor (Faraday's law). The magnetic coil in the body of the instrument generates a magnetic field perpendicular to the flow direction. The magnetic field and the velocity induce a voltage between the electrodes.

The voltage is directly proportional to the flow velocity. The voltage is converted into a flow proportional 4-20 mA output signal or frequency output signal.

Connections to FLOWX3 Instruments

F3.6XM Frequency output is compatible with the list of instruments marked into the following table.

FLOWX3 Magmeter	FLOWX3 Instruments					
	F9.00.L	F9.02.L	F9.03	F9.20	F9.50.L	F9.51.L
F3.60M		■	■		■	■
F3.63M		■	■		■	■

Installation Fittings

Please refer to installation Fittings section for more details and complete listing of items

	Type	Description
	Plastic Tees	Size: D20 to D50 (0.5" to 1.5") Materials: UPVC, CPVC, PP, PVDF
	CPVC Clamp Saddles	Size: D63 to D225 (2" to 8") Insert materials: CPVC, PVDF
	PP Clamp Saddles	Size: D250 to D315 (10" to 12") Insert material: CPVC
	PVC Wafer Fittings	Size: D280 and D315 (10" and 12") Insert material: CPVC
	GR-PP Wafer Fittings	Size: D280 and D315 (10" and 12") Insert material: CPVC
	Plastic Weld-on Adapters	Size: D63 to D315 Materials: UPVC, CPVC, PP, PE
	316L SS Tees	Size: D25 to D40 BSP Female Threaded
	Metal Strap-on Saddles	Size: DN80 to DN450 Insert material: UPVC Special order for other sizes
	316L SS Weld-on Adapters	Size: D50 to D600 (1.5" to 24")

Installation

Different pipe configurations and obstacles in the flow line such as valves, elbows, pipe bends and strainers create variations on the flow profile.

■ The six most common installation configurations are shown to help selecting the best location in the pipe line for the flow sensor.

■ For more information, please refer to EN ISO 5167-1.

■ Always maximize the distance between flow sensor and pump.

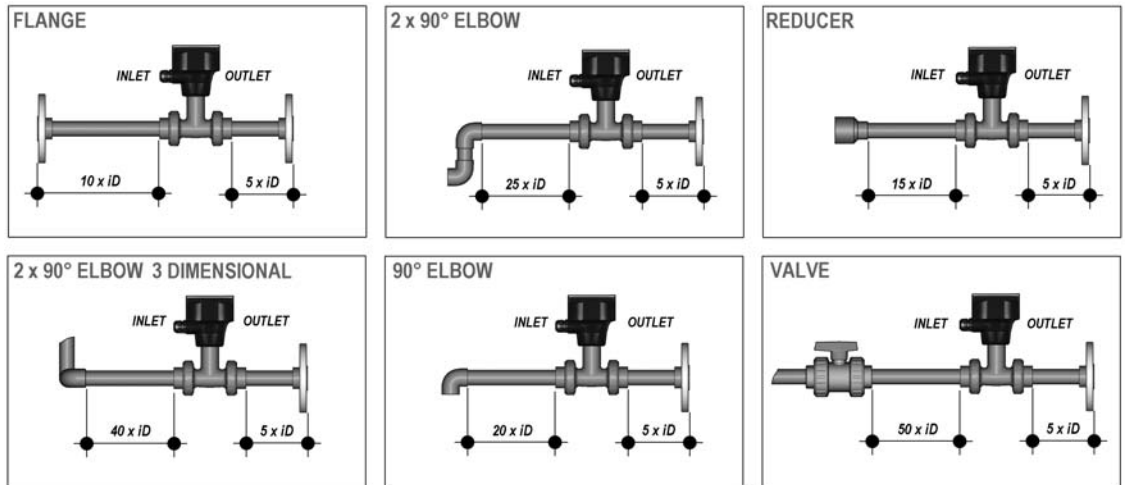

The first three configurations ensure that the pipe is always full: for a correct measurement the sensor can NOT be exposed to air bubbles at any time.

Avoid the other three situations unless you are absolutely sure the sensor is not exposed to air bubbles.

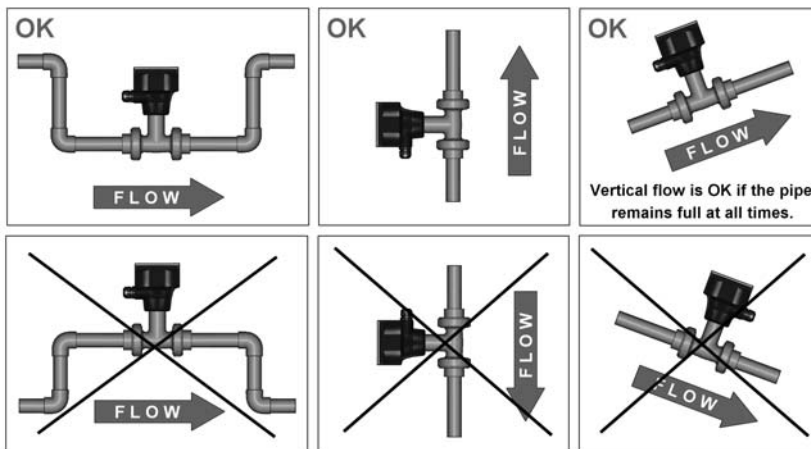

In gravity-flow systems the connection to the tank must be designed so the level does not drop below the outlet: this to avoid pipe to draw air in from the tank causing an erratic measurement of the Magmeter.

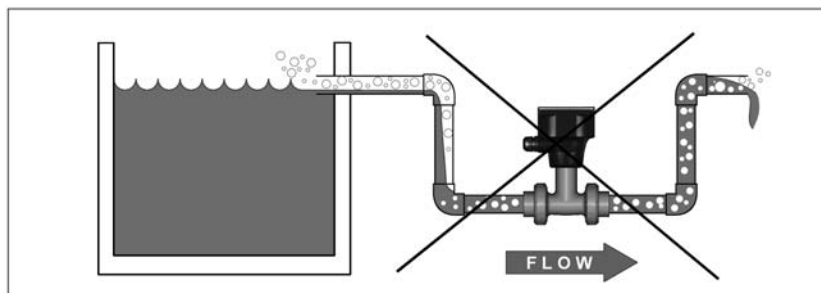

Dimensions

Sensor Body

F3.60M & F3.63M Magmeter

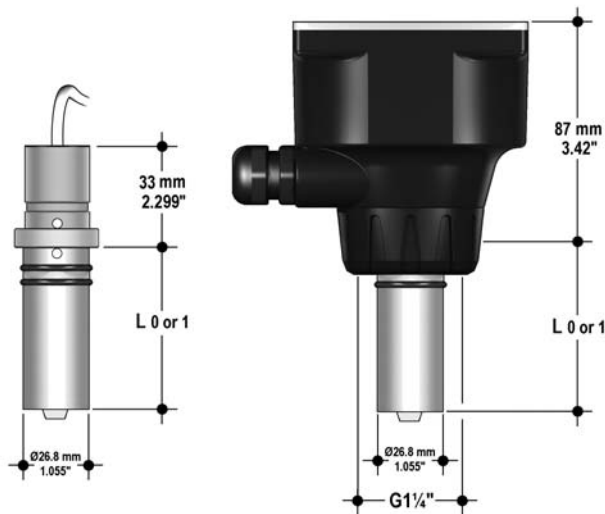

Sensor length:

L0 = 68.5 mm (2.70")

L1 = 98.5 mm (3.88")

Terminal View

Power supply

1	+ VDC
2	+ LOOP
3	- LOOP
4	- VDC

A

Sensor connections

B
F

Open collector OUTPUTS

5	N.C.
6	N.C.
7	N.C.
8	N.C.
9	FREQ +
10	FREQ -

C

F3.63M

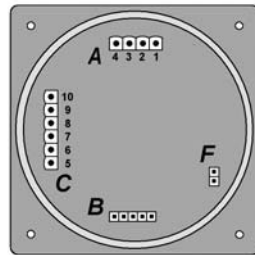

Power supply

1	+ VDC
2	+ LOOP
3	- LOOP
4	- VDC

A

Sensor connections

B
F

Open collector OUTPUTS

5	N.C.
6	N.C.
7	DIR +
8	DIR -
9	FREQ +
10	FREQ -

C

F3.60M

Technical Data

General

- Pipe Size Range: DN15 to DN600 (0.5" to 24"). Please refer to Installation Fitting section for more details.
- Flow Rate Range:
 - F3.60M: from 0.05 to 8 m/s (0.15 to 25 ft/s)
 - F3.63M: from 0.15 to 8 m/s (0.5 to 25 ft/s).
- Full Scale Range : 5 m/s (16,4 ft/s) standard (others available on request).
- Linearity: $\pm 1\%$ of reading + 1,0 cm/s.
- Repeatability: $\pm 0.5\%$ of reading.
- Enclosure: IP65.
- Materials:
 - Case: PC/UPVC
 - Gasket: EPDM.
- Wetted Materials:
 - Sensor body:
 - 316L SS/PVDF
 - 316L SS/PEEK
 - CuNi alloy/PVDF
 - O-rings: EPDM or FPM
 - Electrodes:
 - 316LSS
 - CuNi alloy

Electrical

- Power Supply:
 - 12 to 24 VDC $\pm 10\%$ regulated (reverse polarity and short circuit protected)
 - Maximum current consumption: 150 mA
 - Protective earth: $< 10 \Omega$.
- Current output:
 - 4 - 20 mA, isolated
 - Max. loop impedance: $600 \Omega @ 24 \text{ VDC}$
 - Positive or negative flow indication.
- Frequency output:
 - Open Collector NPN
 - Frequency: 0 – 500 Hz
 - Max. Pull-up Voltage: 24 VDC
 - Max. Current: 50 mA, current limited
 - Compatible with FLOWX3 F9.02.L, F9.03, F9.50.L and F9.51.L.
- Digital output (F3.60M only):
 - Type: Open Collector NPN
 - Max. Pull-up Voltage: 24 VDC
 - Max. Current: 50mA, current limited
 - Flow direction:
 - 0 VDC arrow-wise
 - + VDC anti arrow-wise

Technical Data

Environmental

- Storage Temperature: -10°C to +60°C (14°F to 140°F).
- Ambient Temperature: 0°C to +60°C (32°F to 140°F).
- Relative Humidity: 0 to 95% (non-condensing).
- Fluid conditions:
 - homogeneous liquids, pastes or slurries, also with solid content
 - Min Electrical Conductivity: 20 µS

Temperature:

- PVDF bottom version: -10 °C to +60 °C (14 °F to 140 °F)
- PEEK bottom version: -10 °C to 150 °C (14 °F to 302 °F).
- Max. operating pressure:
 - 16 bar @ 25°C (232 psi @ 77°F)
 - 8.6 bar @ 60°C (124 psi @ 140°F).

Standards & Approvals

- Manufactured under ISO 9001 (Quality).
- Manufactured under ISO 14001 (Environmental Management).
- CE.

Ordering Data

FLOWX3 NEW F3.60M.XX

Part No.	Power Supply	Flow Rate Range	Length	Body/Electrodes	O-ring	Enclosure
F3.60M.09	12 - 24 VDC	0,05 – 8 m/s bi-directional	L0	316L SS & PVDF 316L SS	EPDM	IP65
F3.60M.10	12 - 24 VDC	0,05 – 8 m/s bi-directional	L0	316L SS & PVDF 316L SS	FPM	IP65
F3.60M.11	12 - 24 VDC	0,05 – 8 m/s bi-directional	L1	316L SS & PVDF316L SS	EPDM	IP65
F3.60M.12	12 - 24 VDC	0,05 – 8 m/s bi-directional	L1	316L SS & PVDF316L SS	FPM	IP65
F3.60M.33	12-24 VDC	0,05 – 8 m/s bi-directional	L0	CuNi & PVDF CuNi	EPDM	IP65
F3.60M.34	12-24 VDC	0,05 – 8 m/s bi-directional	L0	CuNi & PVDF CuNi	FPM	IP65
F3.60M.35	12-24 VDC	0,05 – 8 m/s bi-directional	L1	CuNi & PVDF CuNi	EPDM	IP65
F3.60M.36	12-24 VDC	0,05 – 8 m/s bi-directional	L1	CuNi & PVDF CuNi	FPM	IP65
F3.60M.38	12-24 VDC	0,05 – 8 m/s bi-directional	L0	316L SS & PEEK 316L SS	FPM	IP65
F3.60M.40	12-24 VDC	0,05 – 8 m/s bi-directional	L1	316L SS & PEEK 316L S	FPM	IP65

FLOWX3 NEW F3.63M.XX

Part No.	Power Supply	Flow Rate Range	Length	Body/Electrodes	O-ring	Enclosure
F3.63M.09	12 - 24 VDC	0,15 - 8 m/s mono-directional	L0	316L SS & PVDF316L SS	EPDM	IP65
F3.63M.10	12 - 24 VDC	0,15 - 8 m/s mono-directional	L0	316L SS & PVDF 316L SS	FPM	IP65
F3.63M.11	12 - 24 VDC	0,15 - 8 m/s mono-directional	L1	316L SS & PVDF 316L SS	EPDM	IP65
F3.63M.12	12 - 24 VDC	0,15 - 8 m/s mono-directional	L1	316L SS & PVDF 316L SS	FPM	IP65
F3.63M.33	12-24 VDC	0,15 - 8 m/s mono-directional	L0	CuNi & PVDF CuNi	EPDM	IP65
F3.63M.34	12-24 VDC	0,15 - 8 m/s mono-directional	L0	CuNi & PVDF CuNi	FPM	IP65
F3.63M.35	12-24 VDC	0,15 - 8 m/s mono-directional	L1	CuNi & PVDF CuNi	EPDM	IP65
F3.63M.36	12-24 VDC	0,15 - 8 m/s mono-directional	L1	CuNi & PVDF CuNi	FPM	IP65
F3.63M.38	12-24 VDC	0,15 - 8 m/s mono-directional	L0	316L SS & PEEK 316L SS	FPM	IP65
F3.63M.40	12-24 VDC	0,15 - 8 m/s mono-directional	L1	316L SS & PEEK 316L SS	FPM	IP65

Spare Parts

Mechanical Replacements

Item	Part No.	Name	Description
1	F3.KC1	Magmeter Compact mounting kit	Plastic adapter with gasket, compact cap, locking ring and 4 fixing screws
2	F9.SP4.1	PG 13.5	PG 13.5 Cable Gland for Compact kit
2	F9.SP4.2	PG 11	PG 11 Cable Gland for Compact kit
3	F3.SP3.1	O-Rings	EPDM Sensor body O-Rings
3	F3.SP3.2	O-Rings	FPM Sensor body O-Rings

Spare Parts

F3.60M Electronic Replacements

Item	Part No.	Name	Description
1	F3.60M.SP1	Electronic device	Magmeter electronic device with 4-20 mA output and freq. output for bi-directional sensor
2	F3.60M.SP09	Magmeter bi-directional flow sensor	316L SS/PVDF body - EDPM O-Rings - L0 length
2	F3.60M.SP10	Magmeter bi-directional flow sensor	316L SS/PVDF body - FPM O-Rings - L0 length
2	F3.60M.SP11	Magmeter bi-directional flow sensor	316L SS/PVDF body - EDPM O-Rings - L1 length
2	F3.60M.SP12	Magmeter bi-directional flow sensor	316L SS/PVDF body - FPM O-Rings - L1 length
2	F3.60M.SP33	Magmeter bi-directional flow sensor	CuNi/PVDF body - EPDM O-Ring - L0 length
2	F3.60M.SP34	Magmeter bi-directional flow sensor	CuNi/PVDF body - FPM O-Ring - L0 length
2	F3.60M.SP35	Magmeter bi-directional flow sensor	CuNi/PVDF body - EPDM O-Ring - L1 length
2	F3.60M.SP36	Magmeter bi-directional flow sensor	CuNi/PVDF body - FPM O-Ring - L1 length
2	F3.60M.SP38	Magmeter bi-directional flow sensor	AISI 316L/PEEK body - FPM O-Ring - L0 length
2	F3.60M.SP40	Magmeter bi-directional flow sensor	AISI 316L/PEEK body - FPM O-Ring - L1 length

F3.63M Electronic Replacements

Item	Part No.	Name	Description
1	F3.63M.SP1	Electronic device	Magmeter electronic device with 4-20 mA output and freq. output for mono-directional sensor
2	F3.63M.SP09	Magmeter mono-directional flow sensor	316L SS/PVDF body - EDPM O-Rings - L0 length
2	F3.63M.SP10	Magmeter mono-directional flow sensor	316L SS/PVDF body - FPM O-Rings - L0 length
2	F3.63M.SP11	Magmeter mono-directional flow sensor	316L SS/PVDF body - EDPM O-Rings - L1 length
2	F3.63M.SP12	Magmeter mono-directional flow sensor	316L SS/PVDF body - FPM O-Rings - L1 length
2	F3.63M.SP33	Magmeter mono-directional flow sensor	CuNi/PVDF body - EPDM O-Ring - L0 length
2	F3.63M.SP34	Magmeter mono-directional flow sensor	CuNi/PVDF body - FPM O-Ring - L0 length
2	F3.63M.SP35	Magmeter mono-directional flow sensor	CuNi/PVDF body - EPDM O-Ring - L1 length
2	F3.63M.SP36	Magmeter mono-directional flow sensor	CuNi/PVDF body - FPM O-Ring - L1 length
2	F3.63M.SP38	Magmeter mono-directional flow sensor	AISI 316L/PEEK body - FPM O-Ring - L0 length
2	F3.63M.SP40	Magmeter mono-directional flow sensor	AISI 316L/PEEK body - FPM O-Ring - L1 length

Replacement must be done in factory exclusively due to recalibration necessity of the whole instrument.

Mechanical Replacements

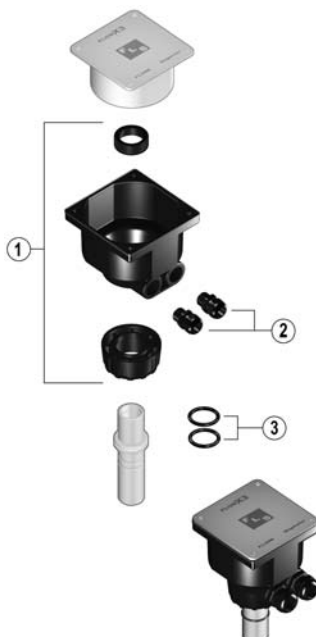

Electronic Replacements

